

# FT-5 3D Printer

## Owner's Manual

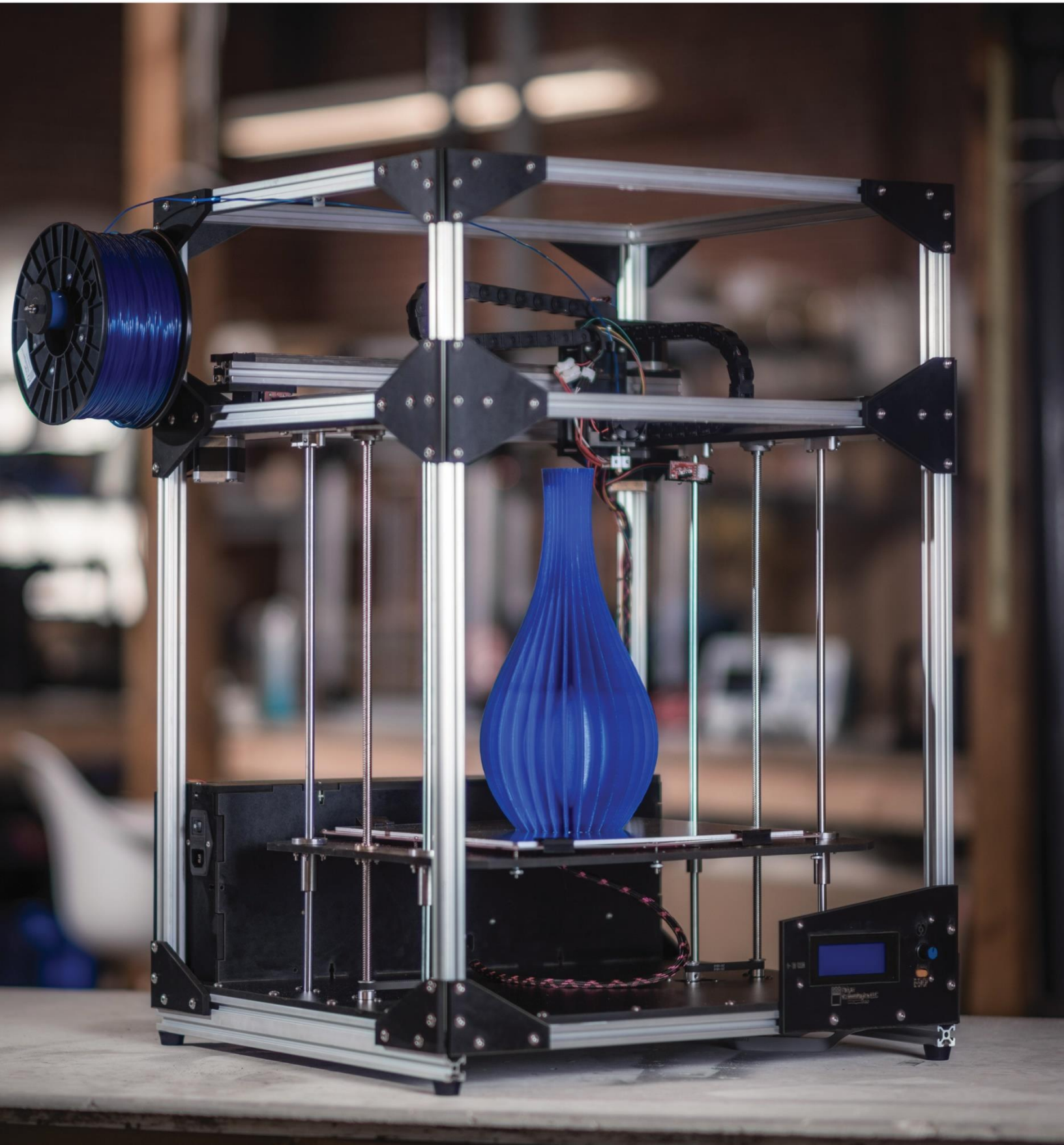

# Table of Contents

## CONTENTS

Introduction .....	3
Contact Folger Tech .....	3
Inventory of Parts .....	4
Folger Tech FT-5 Parts .....	4
Folger Tech FT-5 Hardware.....	5
Folger Tech FT-5 Laser Cut Parts .....	5
Printer Features & Definitions .....	12
Printer Assembly.....	16
1) Assemble the Frame.....	17
2) Assemble the Base Plate .....	22
3) Assemble the Top Plate.....	24
4) Install Base and Top Plate.....	25
5) Assemble Bed Plate.....	26
6) Mounting Bed.....	27
7) Assemble Y Gantry Rails .....	30
8) Gantry Assembly.....	33
9) Hotend.....	37
10) Endstops and Belts .....	43
11) Mounting Electronics and Spool Mount.....	49
12) Assemble and Mount Heated Bed.....	53
13) Wiring .....	56
Testing and Calibration .....	67
ELECTRONICS Check List .....	68
Software .....	70
Connect to the Printer & Loading Firmware .....	70
Verify the Endstops .....	71
Verify Motor Direction and Homing .....	73
Adjusting Z Height .....	74
Verify the Hot End Temperature .....	75

Verify the Extruder .....	76
Software Parameter Setup.....	77
Setting Up A Printer Profile in Cura .....	77
Printing Settings .....	81
Printing Setting Definitions.....	81
Generating G-code using Cura .....	87
Step-by-Step Process .....	87
3) Printing from an SD Card .....	89
Step-by-step Process .....	89
Printer Operation.....	90
Changing Filament .....	90
Bed Preparation.....	91
Maintenance.....	92
Check Belt Tension .....	92
Check for loose screws .....	92
TroubleShooting .....	92

## INTRODUCTION

Congratulations! If you are looking over this manual it means that you are the proud owner of a Folger Tech FT-5 3D Printer, which is a powerful tool that can help you unleash your creative spirit.

Our goal as a company is to provide affordable 3D printers to consumers worldwide. On top of this we want everyone's first printing experience to be a great one. So this User Manual was assembled to provide guidance in assembling and understanding common procedures while using our 3D printer. It covers everything from assembly to the maintenance required to keep your printer performing like new.

We look forward to helping you succeed in the exciting world of 3D printing and giving you everything you need to unlock your innovation.

**NOTE:** Do not soak the melamine parts in water or cleaning products. You may wipe them down with a damp rag but do not soak them. It will cause the parts to swell and/or break.

## CONTACT FOLGER TECH

We understand that manual only covers the basics of your Folger Tech printer, so if at any time you need more assistance, visit our support page at [Folger Tech Support](#) to send us a **message or give** us a call at (888) 397 – 8160 and we will be happy to address your question or concern.

**DISCLAIMER OF LIABILITY:** FOLGER TECHNOLOGIES LLC specifically DISCLAIMS LIABILITY FOR INCIDENTAL OR CONSEQUENTIAL DAMAGES and assumes no responsibility or liability for any loss or damage suffered by any person as a result of the use or misuse of any of the information or product. FOLGER TECHNOLOGIES LLC assumes or undertakes NO LIABILITY for any loss or damage suffered as a result of the use, misuse or reliance on the information and or product. **USE AT YOUR OWN RISK:** Never leave your printer unattended. This kit involves working with 110v/220v and should only be done if you are qualified, if you are not, speak to a qualified electrician.

## INVENTORY OF PARTS

This section lists the individual parts included in the Folger Tech FT-5 3D Printer Kit. Parts are itemized by number and hardware is itemized by letter. It may be helpful to use these tables as a guide to help you navigate this manual.

### FOLGER TECH FT-5 PARTS

Item ID	Quantity	Description	Item ID	Quantity	Description
1	4	700mm 2020 Beam	35	1	2004 LCD Screen
2	7	500mm 2020 Beam	36	1	MKS Board
3	6	460mm 2020 Beam	37	3	Endstop
4	2	500mm 2040 Beam	38	1	LCD Extension Cable
5	3	Slider Rail	39	1	Kapton Tape
6	4	500mm M8 PCR	40	1	Ceramic Screw Driver
7	2	500mm M8 Leadscrew	41	1	Filament Sample
8	6	5.0 kg/cm Motor	42	1	Spool Holder PVC
9	8	SHF8	43	1	150mm M5 Threaded Rod
10	4	KFL8	44	4	3/8 Inch Wire Heatshrink
11	4	LM8FLUU	45	1	Bed Thermistor
12	4	Rubber Foot	46	2	Green Female Block
13	2	T8 Leadscrew Nut	47	1	4pin XH (Both Ends)
14	5	20T 5mm Bore Pulley	48	1	CH2 Springs Connectors
15	2	20T 8mm Bore Pulley	49	2	Green Male Blocks
16	2	GT2 188 Belt Loop	50	2	2 Pin XH
17	3	Idler Pulley	51	1	3 Pin XH
18	4 meter	GT2 Belt	52	2	4 Pin XH
19	1	MK9	53	3	1 Meter Motor Wire W XH 4 Pin
20	1	Heat Sink Fin	54	2	2 Meter Motor Wire with XH 4 Pin
21	2	Fan	55	1	Motor Wire Pigtail W JST Connector
22	1	AL Upper Block	56	2 meter	Red 14 AWG
23	1	M6 PTFE Threaded Tube	57	.5 meter	Green 14 AWG
24	1	3D Hotend	58	1 meter	Red & Black 14 AWG
25	1	300x300 Alum Heatbed	59	2	2 Meter Green 24 AWG
			60	1	1 Meter Red 24 AWG
27	1	Power Supply	61	1	1 Meter Black 24 AWG
28	1	AC Power Cord	62	1	1.5 Meter Green 24 AWG
29	1	USB Port	63	1	1.5 Meter Red 24 AWG
30	1	Power Outlet	64	1	1.5 Meter Black 24 AWG
31	1 meter	Cable Chain	65	1	1.6 Meter Red 18 AWG
32	2	Cable Chain End Female	66	1	1.6 Meter Black 18 AWG
33	2	Cable Chain End Male	67	2 meter	Braided Wire Cover
34	1	USB Cable A-A			

## FOLGER TECH FT-5 HARDWARE

Item ID	Total Supplied	Description	Item ID	Total Supplied	Description
A	56	M3 Nylock Nut	S	12	M4 Nylock Nut
B	26	M3 T-nut	T	8	M4x8 Screw
C	12	M3 Flat Washer	U	4	M4x10 Screw
D	19	M3 Square Nut	V	8	M4x16 Screw
E	32	M3x8 Screw	W	16	M4x20 Screw
F	14	M3x10 screw	X	2	M5 Nylock Nut
G	12	M3x12 Screw	Y	164	M5 T-nut
H	48	M3x16 Screw	Z	164	M5x10 Screw
I	6	M3x20 Screw	AA	6	Small Cable Clamp
J	12	M3x30 Screw	AB	4	Large Cable Clamp
K	6	M3x40 Screw	AC	15	Black Zip Tie
L	4	M3x45 Screw	AD	10	Printed Estop Button
M	8	M3 Thumb Screw	AE	1	Printed Endstop mount
N	4	L Bracket	AF	4	Binder Clips
O	8	Bed Spring	AG	3	Belt Tensioner Spring
P	4	Med Nylon Spacers	AH	8	M4 Set Screw
Q	8	M4 set screw	AI	2	M3 Set Screws
R	28	M4 T-nut	AJ	2	Fuse

## FOLGER TECH FT-5 LASER CUT PARTS

Item ID	Total Supplied	Description	Item ID	Total Supplied	Description
FT1	13	Corners (4 Bolts)	FT15	1	The Hatch
FT2	8	Corners (5 Bolts)	FT16	1	Bed Plate
FT3	1	Idler Top (4 Bolts Right)	FT17	1	Upper Panel (FR w/ Cable)
FT4	1	Idler (2 Bolts)	FT18	1	Upper Panel (FL)
FT5	1	Y-Belt	FT19	1	Electronics Box (MKS +PS)
FT6	1	Y Endstop Mount	FT20	1	Electronics Box Side (power)
FT7	1	Motor Right	FT21	1	Electronics Box (USB)
FT8	1	Motor/Right/Middle	FT22	1	Electronics Box (Honey Air Vent)
FT9	1	Motor/Right/Top	FT23	1	Bottom Panel (500x500)
FT10	1	Idler (7 Bolts)	FT24	1	Spool Holder (Circle)
FT11	1	Extruder Front Plate	FT25	1	LCD Panel
FT12	1	Extruder Back Plate	FT26	1	Idler Top (4 Bolts Left)
FT13	2	Extruder Chain Mount	FT27	1	Extruder (H)
FT14	1	Extruder (H no holes)	FT28	1	Spool Holder (T-Hut)

1. 700mm 2020 Beam

2. 500mm 2020 Beam

4. 500mm 2040 Beam

3. 460mm 2020 Beam



8. 5.0kg/cm Motor



18. GT2 Belt

14. 20T 5mm Bore Pulley

17. Idler Pulley

15. 20T 8mm Bore Pulley





16. 188mm GT2 Belt Pulley

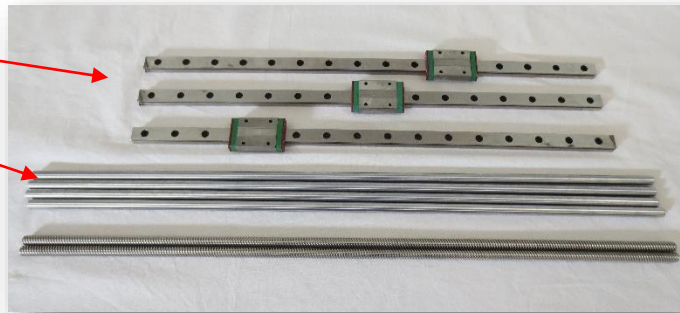

5. Slide Rail

6. 500mm M8 PCB

7. 500mm M8 Leadscrew

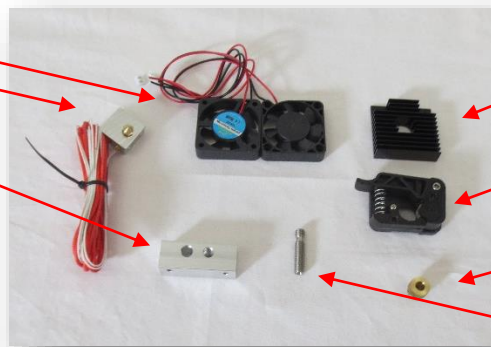

21. Fan

24. 3D Hotend

9. Upper Block

20. Heat Sink Fin

19. MK9

19. Drive Gear (with MK9)

23. M6 PTFE Threaded Tube

35. 2004 LCD Screen

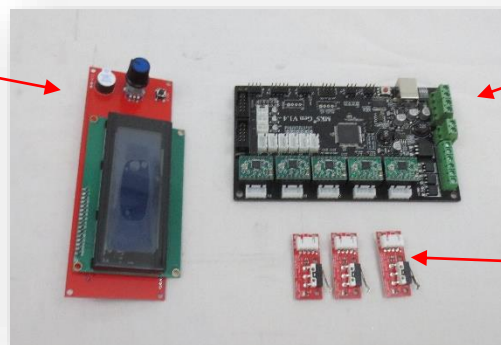

36. MKS Base Board

37. Endstop



25. 300 x 300 Aluminum Heated Bed



28. AC Power Cable

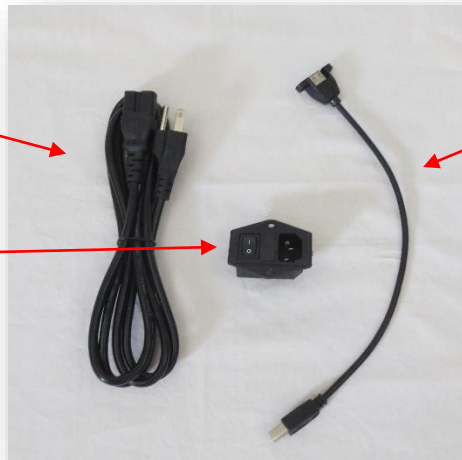

29. USB Port

30. Power Outlet

27. Power Supply

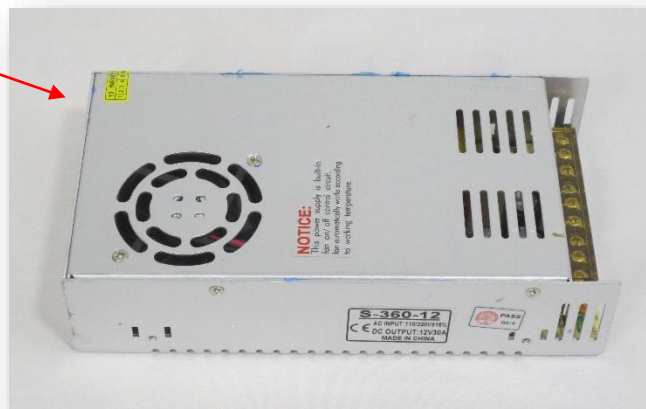

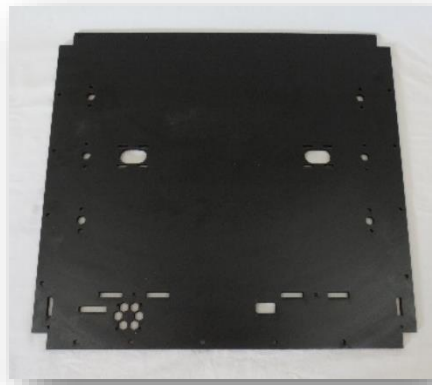

FT23



FT19

FT22

FT17

FT18

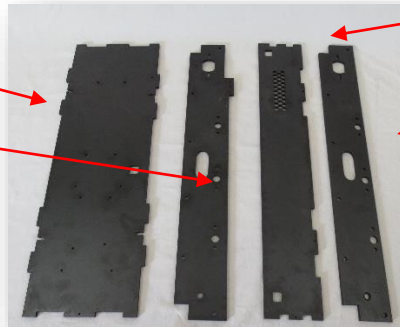

FT15

FT16

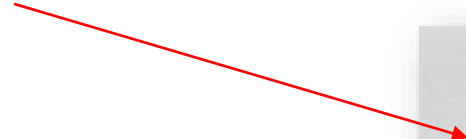
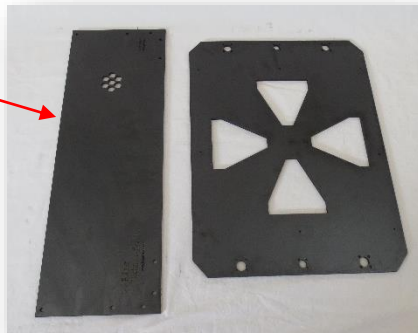

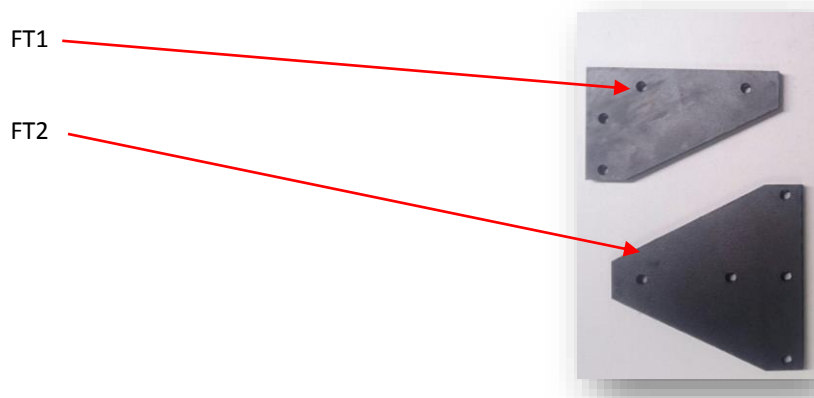
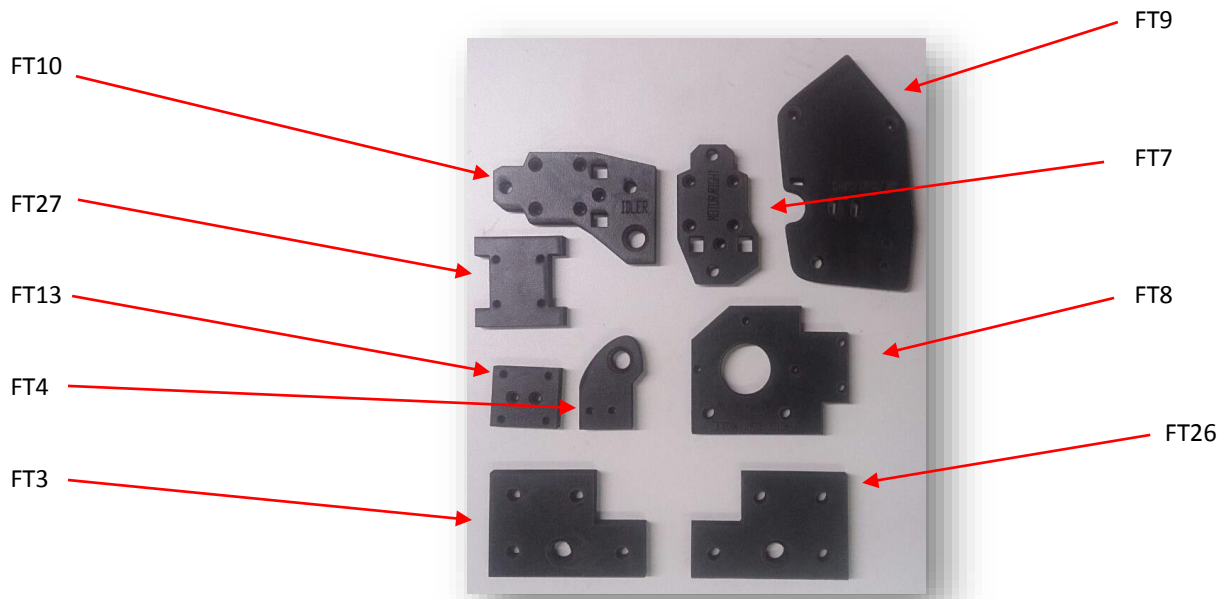
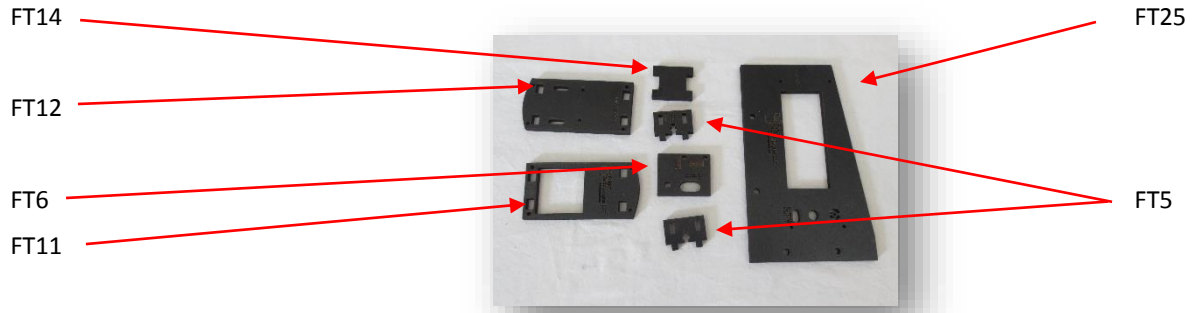

FT21

FT20

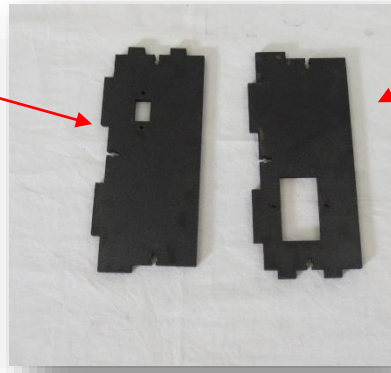

10. KFL8

11. LM8FLUU

12. Rubber Feet

13. T8 Leadscrew Nut

9. SHF8



31. Cable Chain

33. Cable Chain End Male

32. Cable Chain End Female

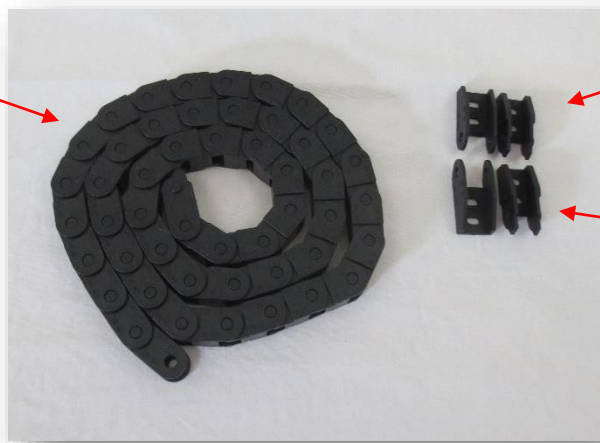

## PRINTER FEATURES & DEFINITIONS

The figure below shows the features of the Folger Tech FT-5 3D printer. You can reference this graphic for clarification of printer parts mentioned in this manual.

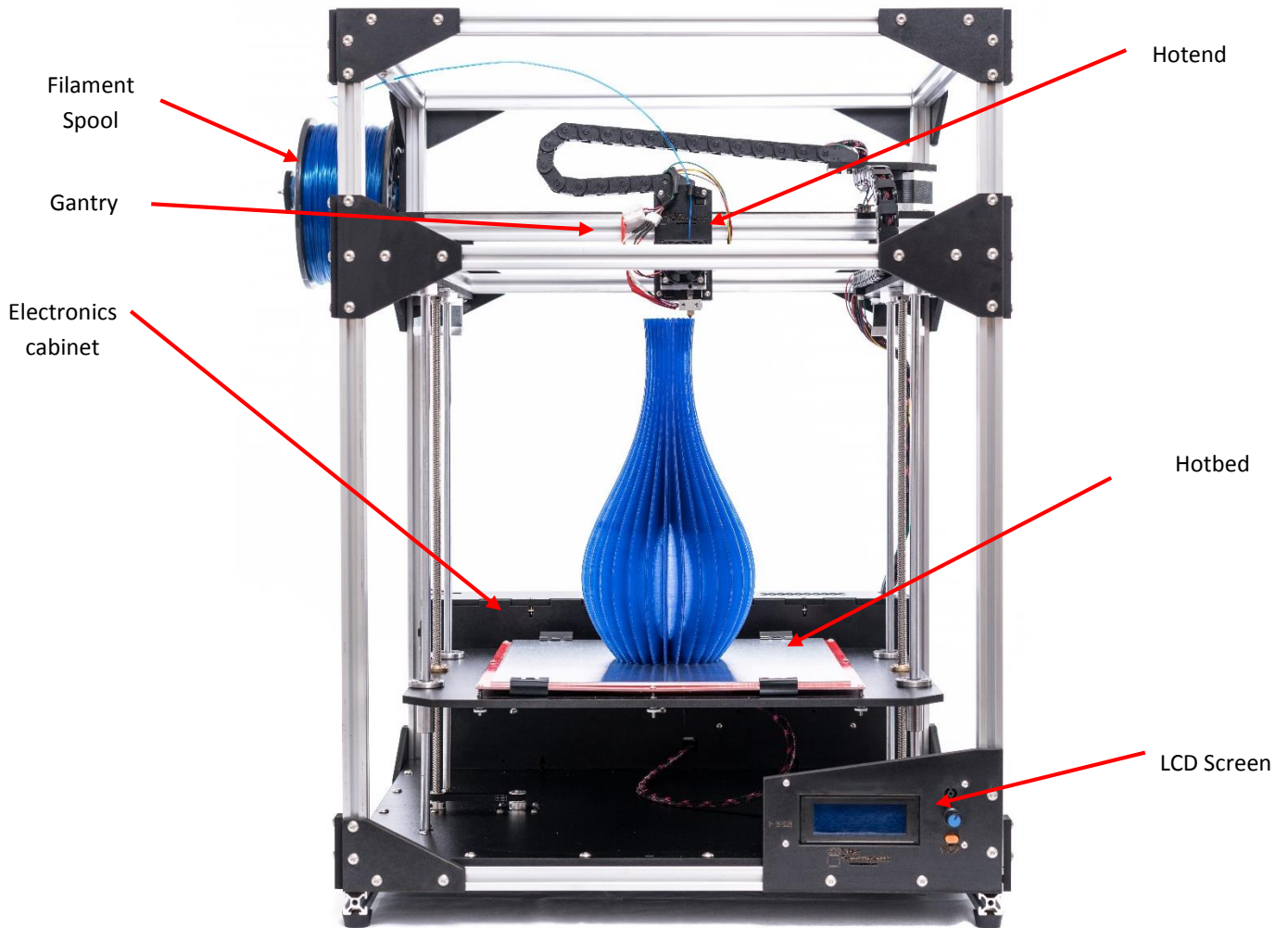

## Nozzle

The nozzle is the brass fitting below the heater block that the plastic extrudes from.

## Hot end

The hot end melts the filament as it gets pushed through the Bowden Tube by the Extruder. It is comprised of the following parts:

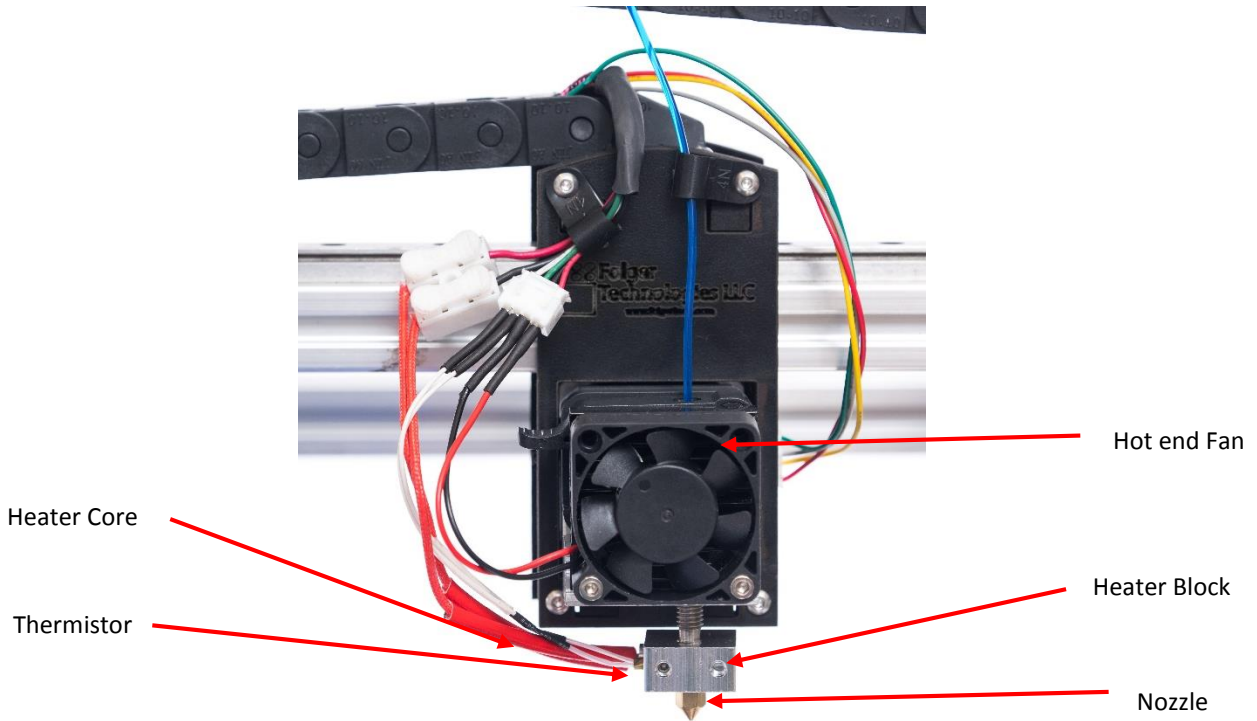

## Gantry

The gantry moves in the Y direction and has the Extruder mounted to it.

## Power Supply

The power supply is what takes the 120 AC from the wall and converts it into 12v DC.

## LCD Screen

The LCD screen is the user interface that controls the printer. To the right of the LCD screen is a speaker (top), control knob (center), and emergency stop button (bottom). Press in the control knob to select a function or rotate it to scroll through the menu options. If the stop button is pressed the machine must be power cycled for functionality to return.

- **Info Screen:** The info screen is the home screen display for the LCD screen.



- **Main Menu:** Press in on the control knob from the info screen to navigate to the Main Menu.
  - Watch – Returns to the home screen
  - Prepare – Option to setup a print (preheat hot end, auto home, cool down, etc.)
  - Control – Change printer firmware settings (temperature, motion, and restore failsafe)
  - Print from SD – Select a file to be printed



- **Prepare:** You can reach this from the Main Menu. The two common features that will be used on this screen are:
  - Auto Home – Zeros the machine and returns the effector to the home position
  - Preheat PLA – Sets the hot end temperature to 200 °C and the bed to 70 °C
  - Preheat ABS – Sets the hotend temperature to 230 °C and the bed to 100 °C





## PRINTER ASSEMBLY

Construction of a Folger Tech FT-5 3D Printer is broken into 13 individual phases and sub-assemblies. The table below shows the different phases required to complete your 3D printer.

<b>Phase</b>	<b>Assembly Description</b>	<b>Page</b>
1	Assemble the Frame	16
2	Assemble the Base Plate	20
3	Assemble the Top Plate	22
4	Install Base and Top Plate	24
5	Assemble Bed Plate	25
6	Mounting Bed	26
7	Assemble Y Gantry Rails	29
8	Gantry Assembly	32
9	Hotend	36
10	Endstops and Belts	42
11	Mounting Electronics and Spool Mount	48
12	Assemble and Mount Heat Bed	52
13	Wiring	54

## 1) ASSEMBLE THE FRAME

In this section, the frame of the FT-5 printer will be assembled.

You will need:

Item ID	Quantity	Description
1	4	700mm 2020 Beam
4	2	500mm 2040 Beam
2	6	500mm 2020 Beam
3	4	460mm 2020 Beam
12	4	Rubber Feet
N	4	L Bracket
FT25	1	LCD Panel
FT1	13	Corner (4 Bolt)
FT2	8	Corner (5 Bolt)
Z	96	M5x10mm Screw
Y	96	M5 T-nut
AH	8	M4 Set Screw

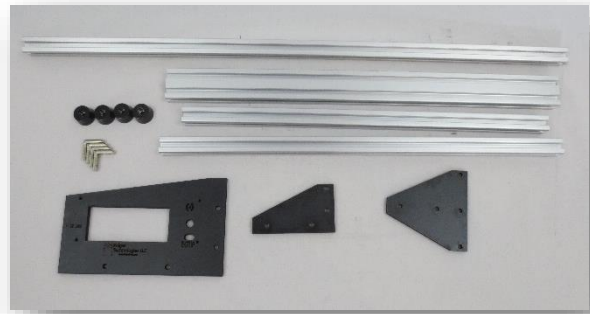

1. Place the 500mm 2040 beam down on the table (standing up). Insert the L bracket so it slides into the upper slot. Insert a 500mm 2020 beam into the other end of the L bracket. Insert two M4 Set screws into the L bracket and lock the corner in place.

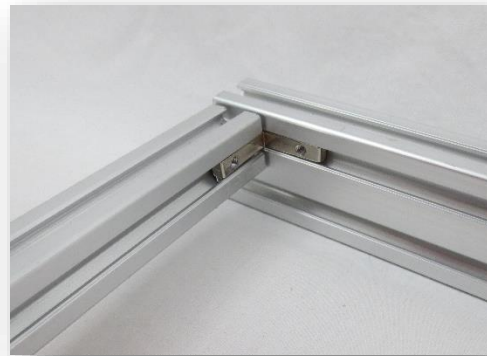

2. Repeat the process from step one until the base is formed.



3. Take a FT1 and insert a M5x10mm screw through each hole and finish them off with a M5 T-nut. **NOTE: Only 13 FT1 will be used. See step 7, there are none used on the bottom rear of the printer.**



4. Place the corner so that the bottom two T-nuts slide into the upper piece of the double AL beam. The end of the corner should line up with the end of the double AL beam. This is the left front of the printer.

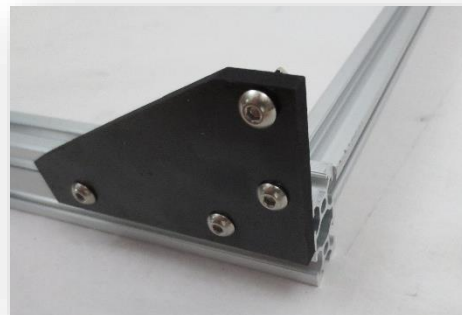

5. Repeat steps 3 and 4 for the other side of the corner. Note this one will have the screws going through the opposite way.



6. Insert the 700m 2020 beam down into all 4 M5 T-nuts. Tighten down the T-nuts and make sure the corner is tight together.

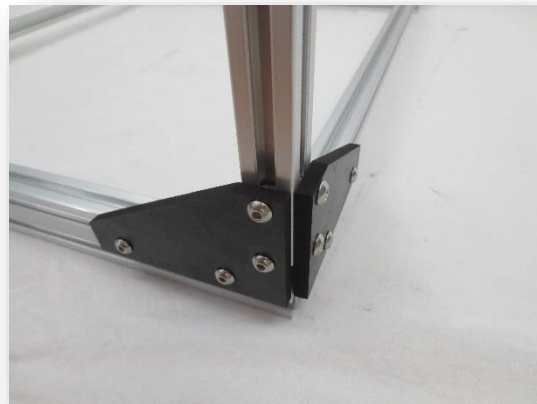

7. The LCD Panel (FT25) attaches to one of the single AL beams and that side is now the front of the machine. Using the same process as steps 3-6, attach three more corners on the frame. **NOTE: The opposite side of the LCD Panel and left corner, the BACK, has no corner pieces on it and will be covered with the back electronics box panel later in this guide.**

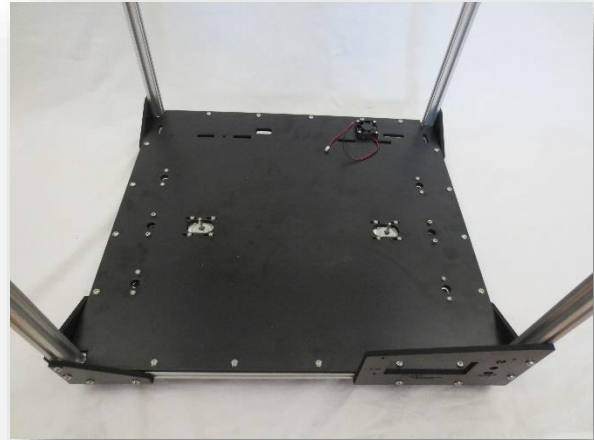

8. Using the same process before, add the top of the frame. Note that the sides use 460mm 2020 beams and the front uses 500mm 2020 beams.



9. Take a middle brace and insert 5 M5x10mm screws into the holes and finish them off using M5xT-nuts.

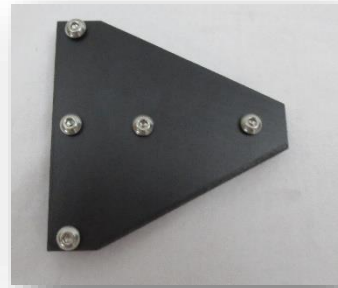

10. Attach it to the vertical AL beams. The inner edge of both beams should be 170mm apart. Attach a 460mm 2020 beam to the middle brace.



11. Repeat steps 9 and 10 on the remaining 7 middle braces. Note that the front and back are 500mm AL beams and the sides are 460mm 2020 beams.

12. Flip the frame over. Put a M5x10mm screw through a rubber foot and finish it off with a M5 T-nut. Attach this to one of the corners on the bottom.

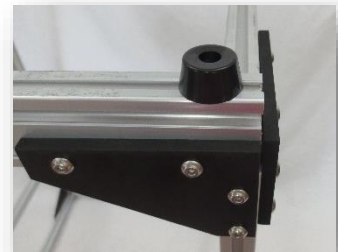

13. Repeat step 12 for the remaining three corners.

## 2) ASSEMBLE THE BASE PLATE

In this section, base panel will be assembled.

You will need:

Item ID	Quantity	Description
8	2	Medium Motor
9	4	SHF8
10	2	KPL8
21	1	Fan (Extruder Sub Kit)
FT23	1	Bottom Panel
A	4	M3 Nylock
C	8	M3 Washer
F	8	M3x10mm Screw
I	4	M3x20mm Screw
S	12	M4 Nylock
V	4	M4x16mm Screw
W	8	M4x20mm Screw



1. Insert the stepper motor through one of the two stepper mounting holes on the Bottom Panel (the top side has the fan hole in the lower left). Secure the motor in place using four M3x10mm screws and four M3 washers. The motor wire connector should point towards the flower fan opening.



2. Repeat the last step for the second stepper motor.



3. Place the fan on the top side over the fan opening. Secure it in place using four M3x20mm screws and four M3 Nylock nuts.

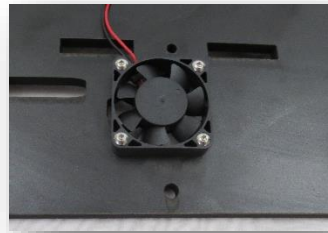

4. Take two SHF8 and one KFL8 and place them on the underside of the Bottom Panel. Secure the two SHF8 in place using two M4x20mm screws and M4 Nylocks. The KFL8 is secured in place using two M4x16mm screws and two M4 Nylocks.



5. Repeat step 4 for the other side of the base plate.

6. With the face of the Bottom Panel pointing up, insert 18 M5 x 10mm screws and finish them off using 18 M5 T-nuts.

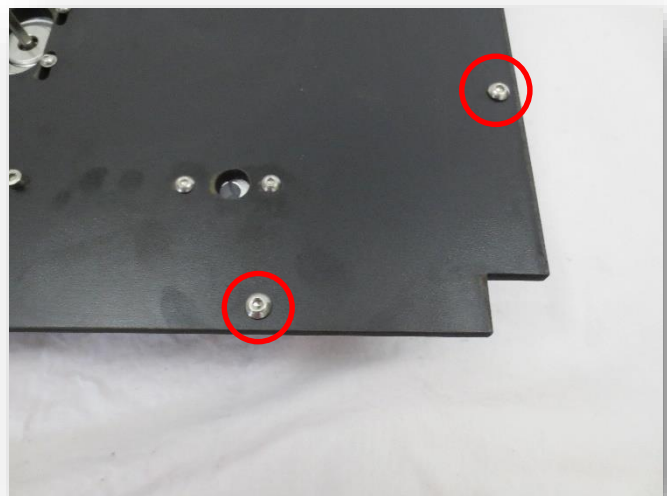



### 3) ASSEMBLE THE TOP PLATE

In this section, the vertical rails will be installed on the base (built in step 1).

You will need:

Item ID	Quantity	Description
8	2	Medium Motors
10	2	KFL8
9	4	SHF8
FT17	1	Upper Panel (FR w/Cable)
FT18	1	Upper Panel (FL)
F	8	M3x10mm Screw
C	8	M3 Washer
V	4	M4x16mm Screw
W	8	M4x20mm Screw
R	24	M4 T-Nut
U	12	M5X10mm Screw
Y	12	M5 T-nut

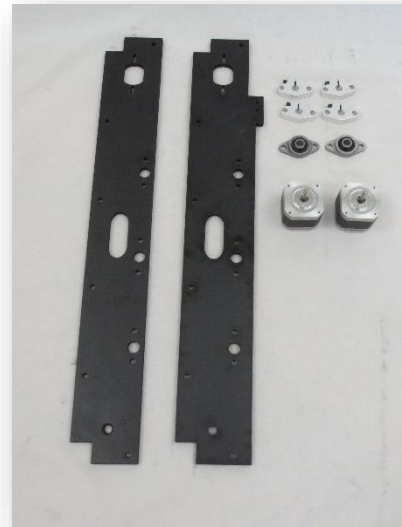

1. With the lettering on one of the Upper Panel facing up, insert one of the stepper motors through. Secure it in place using two M3x10mm screws and two M3 washers. The motor cable connector should face towards the right.

Note: Position the motor all the way to the center of the panel. This will be helpful when adding the belts in a later section.



2. Mount two SHF8 and one KFL8 on the bottom of the middle mounting bracket (same side as the stepper motor). Put the two SHF8 in place using two M4x20mm screws and M4 T-nut. The KFL8 is secured in place using two M4x16mm screws and two M4 T-nut. Leave these a little loose for adjustment later.



3. Insert M5x10mm screws into the remaining six holes and finish them off with six M5 T-nuts. The T-nuts should be on the same side as the rest of the T-nuts.



4. Repeats steps 1-3 for the other Upper Panel.

#### 4) INSTALL BASE AND TOP PLATE

In this section, the base panel and upper panels will be mounted to the frame

You will need:

Item ID	Quantity	Description
	1	Base Panel (Phase 2)
	2	Upper Panel (Phase 3)

1. Flip the machine with the top on the table. Insert the left Upper Panel (FT18) under the center of the frame. All of the outside T-nuts should line up and lock in place.



2. Repeat step 2 on right Upper Panel (FT17)

3. Flip the machine back over and with the LCD corner facing forward, slide the base plate inside the frame and lay it down on the bottom. The 40mm fan should be in the back. Line up all the T-nuts and lock them into place.

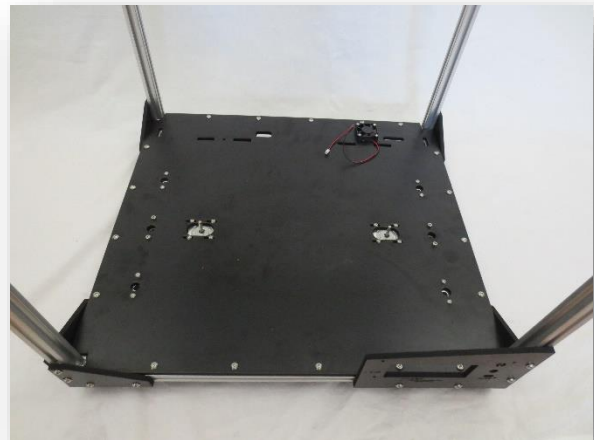

## 5) ASSEMBLE BED PLATE

In this section, the bed panel will be assembled.

You will need:

Item ID	Quantity	Description
FT16	1	Bed Plate
11	4	LM8FLUU
13	2	T8 Leadscrew Nut
H	24	M3x16mm Screw
A	24	M3 Nylock

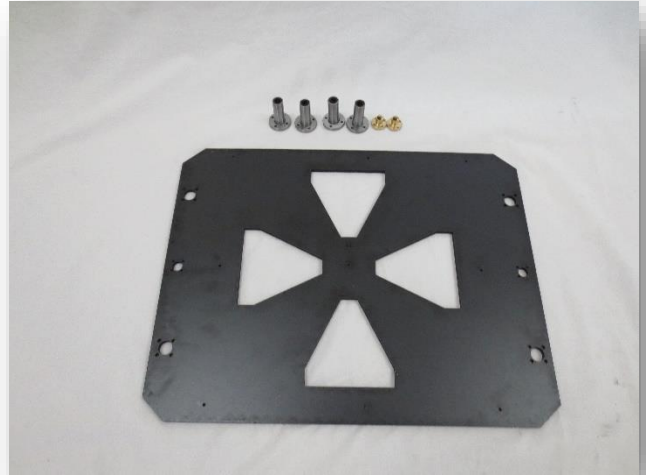

1. Insert two of the LM8FLUU into the outer holes. Secure them in place four M3x 16mm screw and four M3 Nylock. Insert T8 Leadscrew nut into the center holes and secure it in place using four M3x16mm Screws and four M3 Nylocks.



2. Repeat this step for the other side of the hot bed plate.

## 6) MOUNTING BED

In this section, the bed plate will be mounted to the frame.

You will need:

Item ID	Quantity	Description
	1	Bed Plate (phase 5)
6	4	500mm M8 PCR
7	2	500mm M8 Leadscrew
15	2	20T 8mm Bore Pulley
14	2	20T 5mm Bore Pulley
16	2	GT2 188 Belt Loop

1. Insert the four M8 PCR through the SHF8 on the bottom of the frame and through the LM8FLUU on the bed.

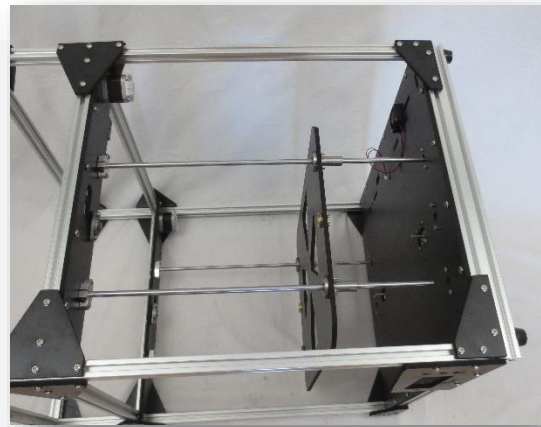

2. Slide the M8 PCR all the way through until the bottom of the rod is flush with the SHF8 on the bottom panel. The top of the chrome rod should slide into the upper SHF8. Tighten the screw on the SHF8 to lock the chrome rod in place. Repeat this for the other three M8 PCR.



3. Take the M8 leadscrew and insert it through the KFL8 located on the bottom of the frame. You may need to loosen the set screws on the KFL8. Take one of the 20T 8mm bore pulleys and one of the GT2 belts and insert them on the threaded rod.

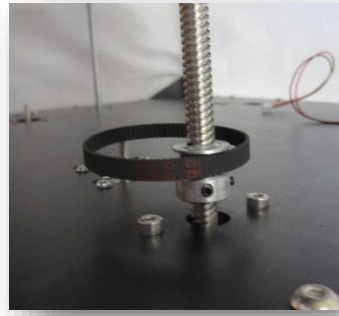

4. Thread the threaded rod through the bed plate and all the way to the KFL8 on the middle mounting bracket.



5. Tighten the set screws on the bottom KFL8.



6. Insert one of the 20T 5mm bore pulleys onto the stepper motor located on the base plate. Loosen the four stepper motor screws and position the belt so it is in both of the toothed grooves on both pulleys. Ensure the belt is strait and tighten the screws on the stepper motor.

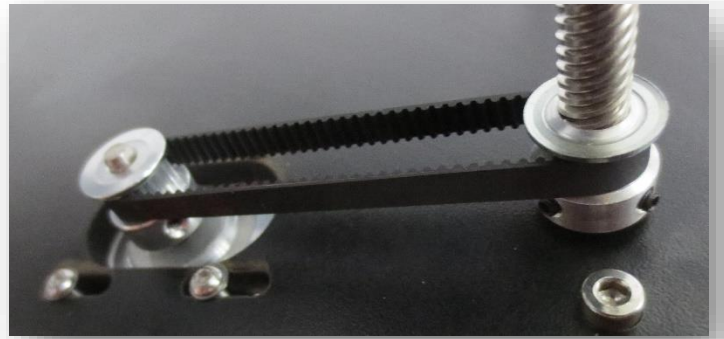

7. Repeat steps 3-6 on the other threaded rod.

## 7) ASSEMBLE Y GANTRY RAILS

In this section, Y gantry rails will be assembled. It is important that the slides on the rails do not fall off.

You will need:

Item ID	Quantity	Description
5	3	Slider Rail
2	2	460mm 2020 Beam
39	1	Kapton Tape
E	32	M3x8mm Screw
B	24	M3 T-nut
D	2	M3 Square nut
H	2	M3x16mm Screw
Z	4	M5x10mm Screw
Y	4	M5 T-nut
FT5	2	Y-Belt
FT10	1	Idler (7 Bolt)
FT7	1	Motor Right

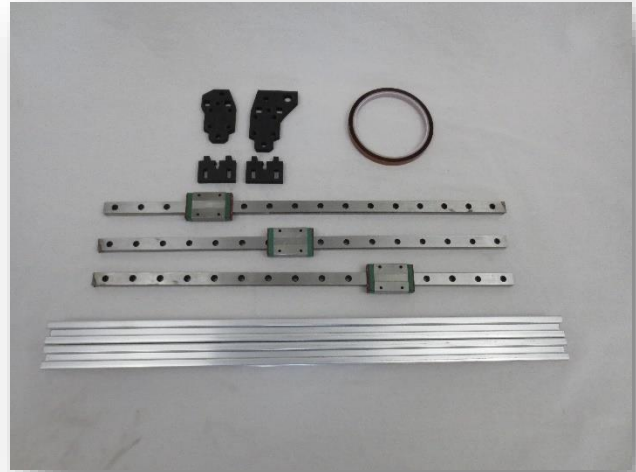

1. Take one of the slider rail, insert a M3x8mm screw into every other hole on the rail. Finish off each one with a M3 T-nut.



2. Repeat step one for the remaining two slider rail.



3. Insert the slider rail onto the 460mm 2020 beam. Center it on the 2020 beam and lock the M3 screws in.

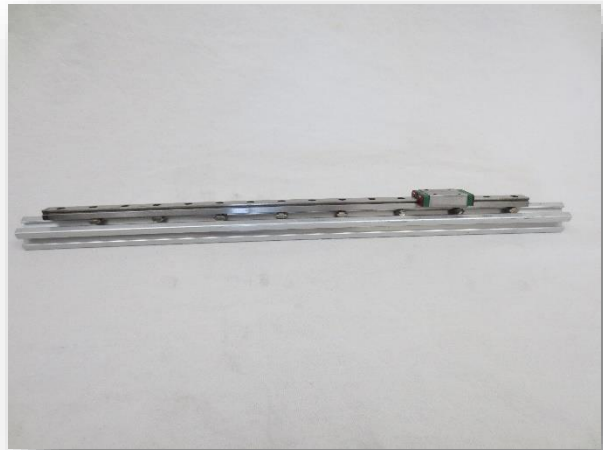

4. Repeat step 3 on the other 2020 beam. The remaining slider rail will be used at a later step.

5. Line up the two rails and align the sliders with each other. Use some kapton tape to lock each one in place. This will prevent the slides from falling off while building and they will be cut free later.

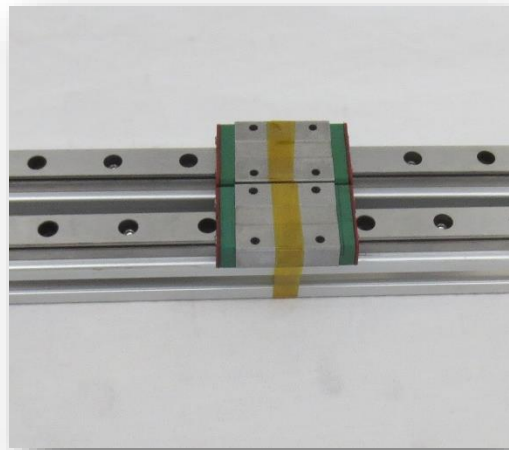



Y Belt Holders

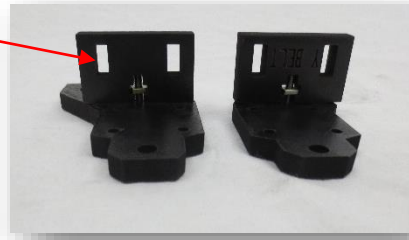

6. Take the FT10, FT7 and slide the FT5 into the two gantry mounts. Insert a M3 square nut into each one and screw in a M3x16mm screw. This will lock the two parts together.



7. Insert two M5x10mm screws into each one and finish them off with two M5 T-nuts.



8. Position the two rails parallel to each other. Set the two laser cut assemblies on top of each slider so that the Y belt holders are on the inside. Secure each one down using four M3x8mm screws.

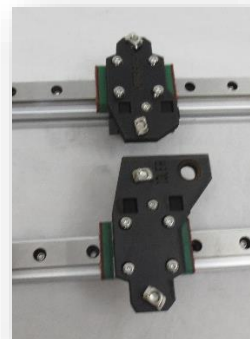

## 8) GANTRY ASSEMBLY

In this section, the extruder will be assembled.

You will need:

Item ID	Quantity	Description
8	1	Medium Motor
14	1	20T 5mm Bore Pulley
17	1	Idler Pulley
37	1	Endstop
2	1	500mm 2020 Beam
	1	Slider Rail (Phase 7)
F	5	M3x10mm Screw
H	2	M3x16mm Screw
B	1	M3 T-nut
A	1	M3 Nylock
Z	4	M5x10mm Screw
Y	4	M5 T-nut
FT8	1	Motor/Right/Middle
FT4	1	Idler (2 Bolt)

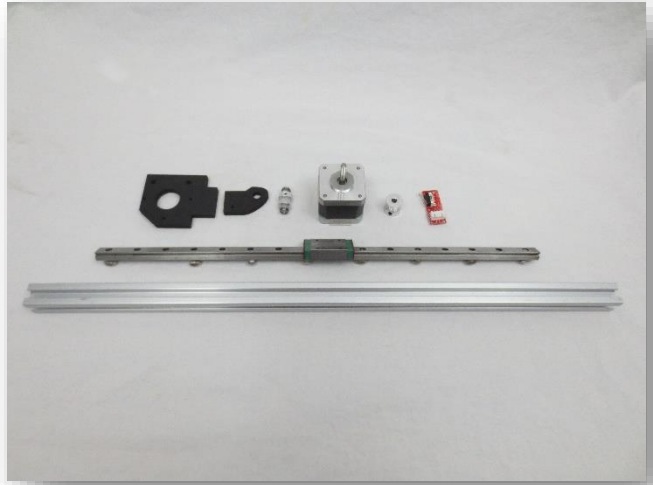

1. Lay the 500mm rail flat on the table. The Y belt should be on the outside.

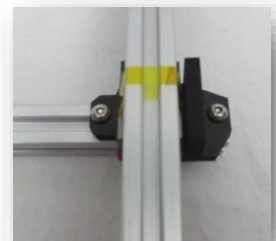

2. Tighten the M5 screws to lock them onto the 500mm beam. The ends should be flush with the laser cut parts. This will be adjusted later to fit into the frame.

3. Take the FT4 Idler (2 bolt) and insert two M3x10mm screws through and finish them off with two M3 T-nuts. **Note:** The countersunk side of the hole should be on the same side as the T-nuts.



4. Take the motor/right/middle and insert two M5x10mm screws through and finish them off with two M5 T-nuts. The lettering should be on the same side as the T-nuts.



5. Place the stepper motor under the motor/right/middle. Use three M3x10mm screws to lock the motor in place.

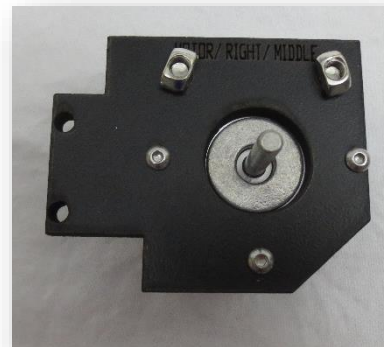

6. Take the limit switch and position it on the same side as the stepper motor. Use two M3x16mm screws and insert them through the motor/right/middle and finish them off with two M3 Nylock.

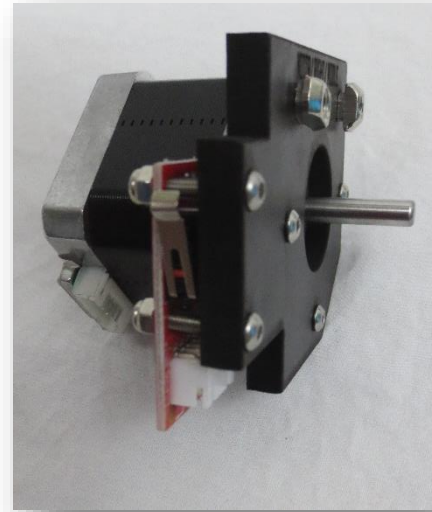

7. Slide the 5mm bore pulley onto the shaft of the stepper motor. Secure it in place by tightening the two set screws on the pulley.



8. Place the idler (2 bolt) on top of the 500mm 2020 beam and hold the idler pulley in between the two holes. The idler should be strait up and down. Lock the two T-nuts and secure the mount in place.



9. Place the slider rail on top of the 2020 beam. The rail should butt up to the idler (2 bolt). Secure the slider rail in place.

**Note:** If the screws were not installed on the slider rail, refer to phase 7 step 1 for details.

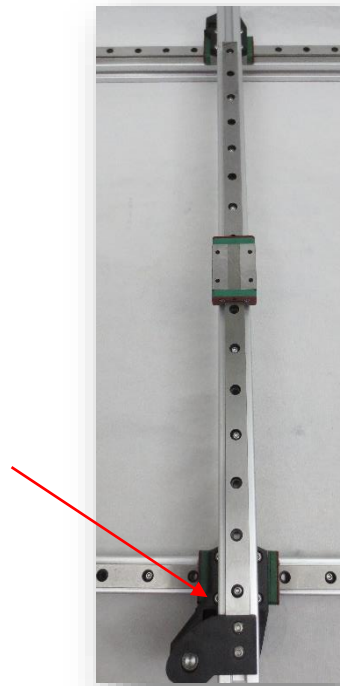

10. Put the stepper motor onto the 2020 beam and butt it up to the rail. The limit switch should be on the inside. Lock this in place using the two M5 screws.

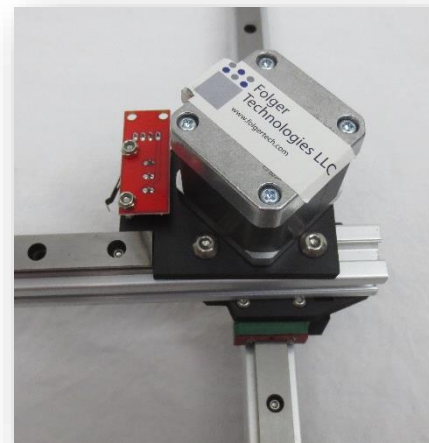

## 9) HOTEND

In this section, the remaining mechanical components will be mounted to the printer.

You will need:

Item ID	Quantity	Description
8	1	Medium Motor
24	1	3D Hotend
23	1	M6 PTFE Tube
22	1	Al Upper Block
20	1	Heat Sink Fin
19	1	MK9
32	2	Female Cable Chain Ends
33	1	Male Cable Chain Ends
A	10	M3 Nylock
G	6	M3x12mm Screw
H	4	M3x16mm Screw
K	6	M3x40mm Screw
L	4	M3x45mm Screw
FT9	1	Motor/Right/Top
FT11	1	Extruder Front Plate
FT12	1	Extruder Back Plate
FT27	1	Extruder (H)
FT13	1	Extruder Chain Mount
FT14	1	Extruder (H no holes)



1. Take the stepper motor and slide the brass drive gear onto the shaft of the motor. Leave a 1 mm gap between the stepper motor and the drive gear. Tighten the set screws on the drive gear.



2. With the motor connector of the stepper motor pointing to the right, slide FT11 on top of the stepper motor. Place the MK9 over the drive gear. You will need to remove the M3 nut from the back of the MK9 to get it to lay flat. Tighten the two M3 screws on the top of the MK9. One is located behind the lever by the spring.



3. Lay the Al upper block on the stepper motor so that the M6 threaded hole is on the left.



4. Lay the heat sink fin on top of the Al upper block. Use two M3x40mm screws to secure it in place. Insert The M6 PTFE tube (aka Barrel) into the right hole and position it flush with the top of the upper block. Secure this in place using a M3 setscrew. Screw on the 3D hotend onto the M6 tube. It may help to remove the heated core and the thermistor.

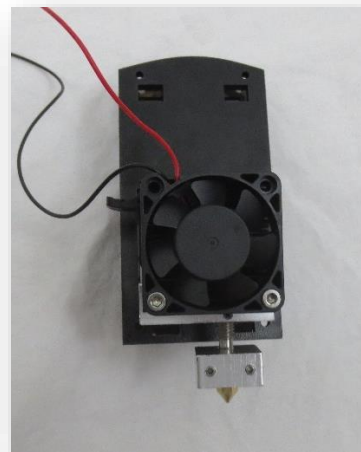

5. Take the FT13 and insert two M3x12mm screws into the two center holes. Slide the Male cable chain end onto the two screws and finish them off with two M3 Nylocks. **Note: Makes sure the male chain is centered and that the four mounting holes are not covered.**



6. Take four M3x16mm screws and insert them through the four holes on the FT13. Then through four holes of the FT27. Make sure the tabs perpendicular to the male cable chain. Place this over the X slide on the gantry and tighten the M3 screws down.

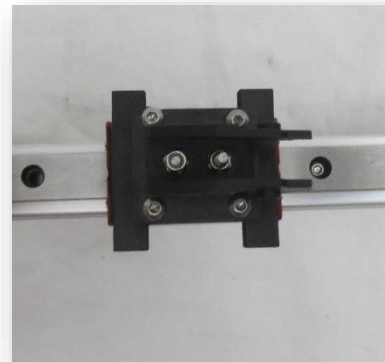

7. Insert FT14 into the two slots on the FT11. Remove the two **top** screws on the back of the stepper motor.





8. Use two M3x40mm screws to secure FT12 to the back of the stepper motor.



9. Slide the hotend assembly over the tabs of the top FT27. Lock this in place using four M3x45mm screws and four M3 Nylock. There are two screws on top and two on bottom.

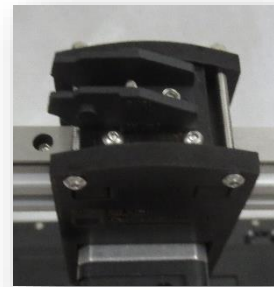

10. Take FT9 and lay it face down. Take a female cable mount and secure it in place using two M3x12mm screws and two M3 Nylocks.



11. Flip FT9 over and place a female cable mount over the two holes. Secure it in place using two M3x12mm screw and two M3 Nylock.



12. Remove two of the screws from the back of the stepper motor.

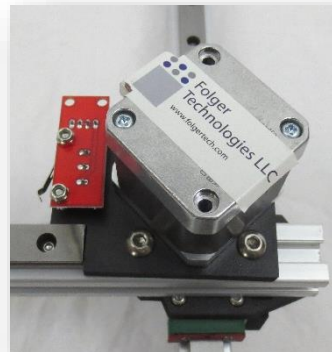

13. Place FT9 over the back of the stepper motor. Secure it in place using two M3x40mm screws.

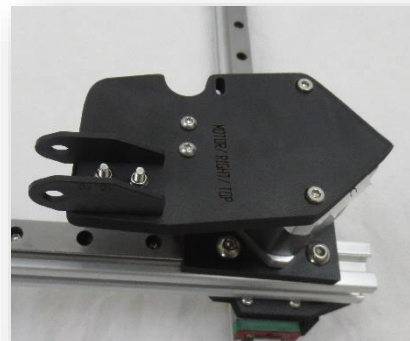

14. Take the gantry assembly and place it into the frame on top of the two upper panels. Clip the kapton tape off each rail. You will need to adjust the position of the slides to get it to fit.

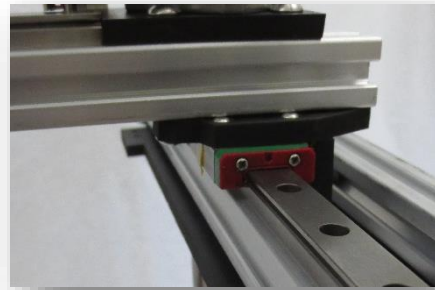

15. You may need to adjust the gap between each rail. Loosen the two M5 screws on either the X motor mount or the idler.

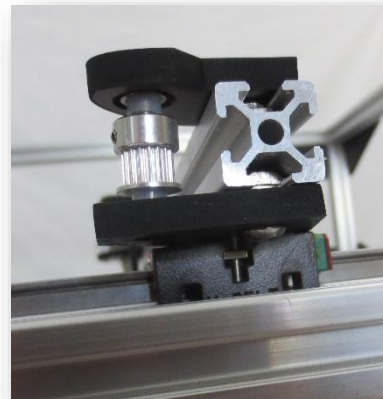

16. When the two 2020 beams are seated on all of the T-nuts, tighten the T-nuts and lock them in place.



17. Make sure the gantry moves smoothly. You may need to adjust the Y rails on the 2020 beams to make sure they are parallel to each other.

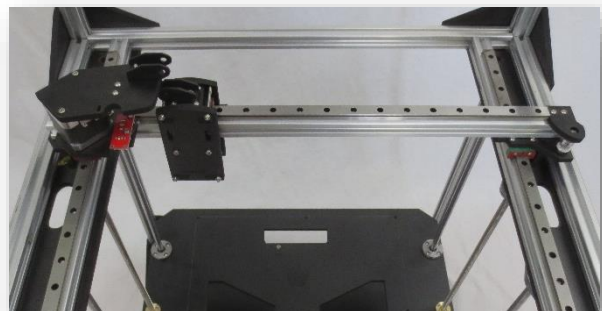

## 10) ENDSTOPS AND BELTS

In this section, the GT2 belts will be mounted

You will need:

Item ID	Quantity	Description
14	2	20T 5mm Bore Pulley
17	2	Idler Pulley
31	1 meter	Cable Chain
A	7	M3 Nylock
G	5	M3x12mm Screw
I	3	M3x20mm Screw
Z	9	M5x10
Y	9	M5 T-nut
AC	6	Zip Ties
18	4 meter	GT2 Belt
FT3	1	Idler (4 Bolts Right)
FT6	1	Y endstop Mount
FT26	1	Idler (4 Bolts Left)

18. Take FT3 and insert four M5x10mm screws and finish them off using four M5 T-nuts. Repeat this for the other FT26. They should be mirror of each other.

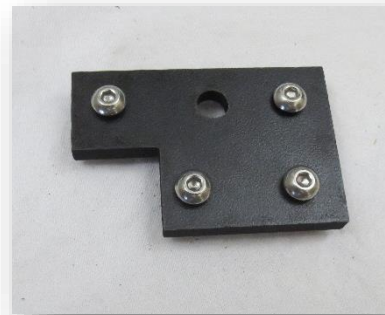

19. Place an idler pulley into the hole on the Y axis. Place FT3 over the idler pulley and one of the screws in place. This will be removed later when adding the belts. Repeat this for the other y axis idler pulley.

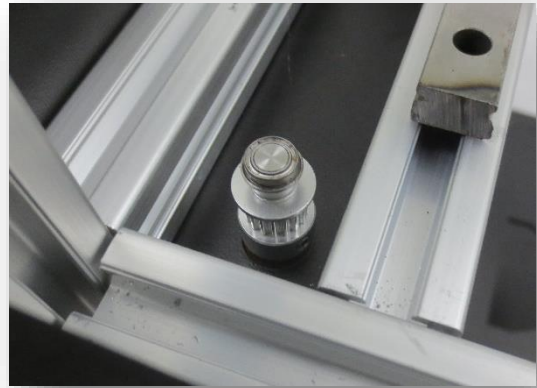
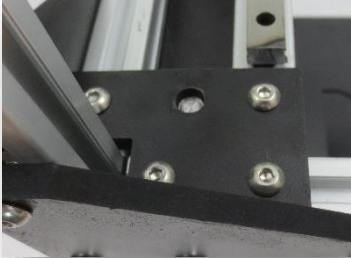

20. Take a 5mm bore pulley and place it onto the shaft of one of the y axis stepper motors. Lock it in place using the two set screws. Repeat this for the other y axis stepper motor.

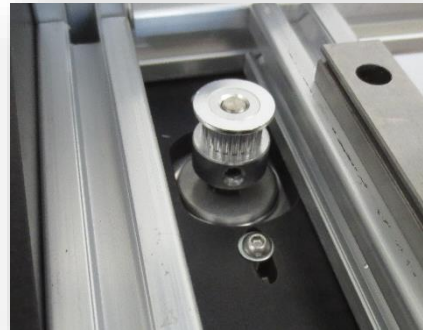

21. Take the cable chain and split it in half (20 links, note using more than 20 links will cause the cables to be too short). Take one end and lock it into the female cable mount on the x axis motor. Lock the other end onto the male cable mount on top of the hotend.

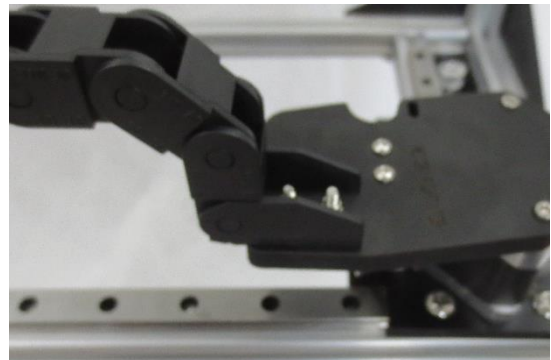
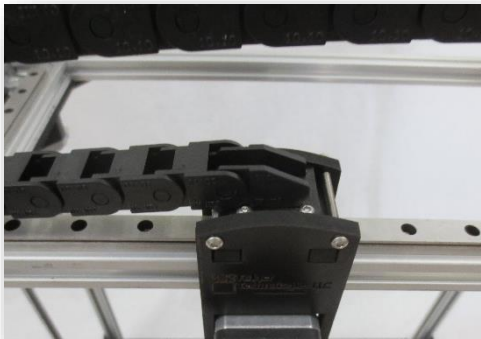

22. Take a male cable mount and secure it in place on the right upper panel using two M3x12mm screws and two M3 Nylocks.

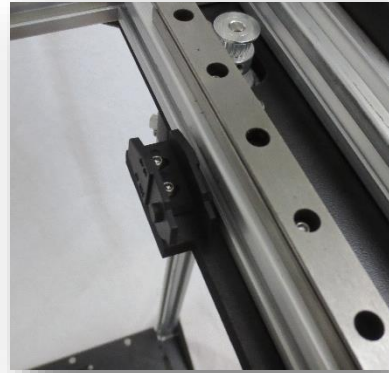

23. Snap one end of the other section (about 19 links, note using more than 19 links will cause the cables to be too short) of cable chain onto the male cable mount. Secure the other end of the cable chain onto the female cable mount.

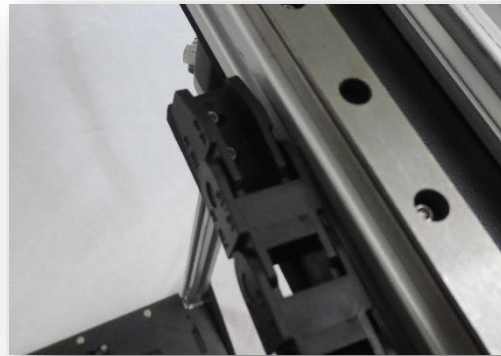
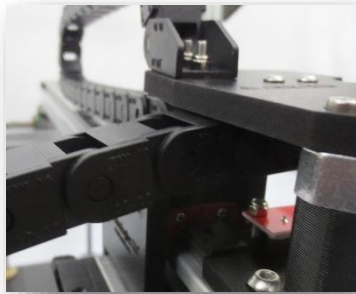

24. Take FT6 and secure an endstop using two M3x12mm screws and two M3 Nylocks. Insert a M5x10mm screw and finish it off using a M5 T-nut.

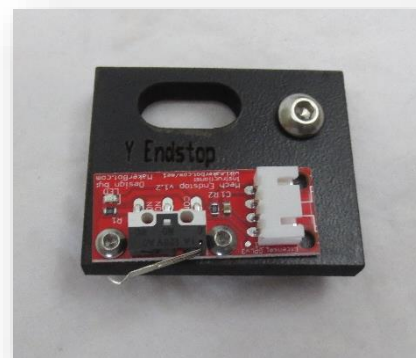

25. Place the limit switch onto the right side of the frame. Lock it in place using the M5 screw. This can be adjusted later to calibrate the printer.

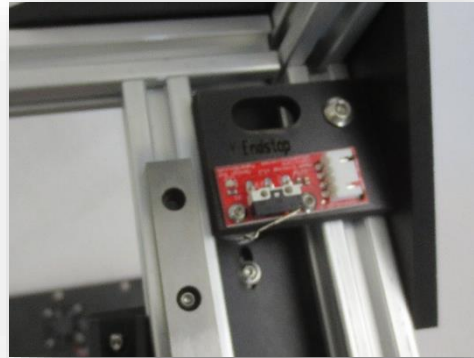

26. Take printed endstop mount and an endstop and secure it in place using two M3x20mm screws and two M3 Nylocks.

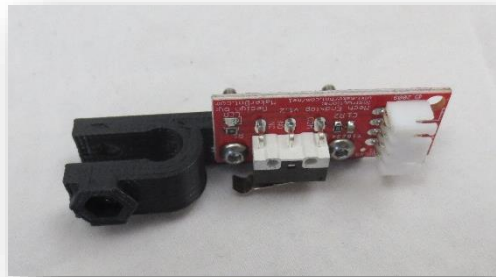

27. Position the endstop onto the back right M8 PCR. Insert a M3x20mm screw through the end and finish it with a M3 Nylock. This will be adjusted during calibration.

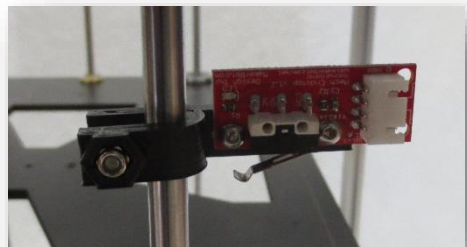

28. Take the GT2 Belt and cut a one-meter length of it. Loop one end of it into the left Y-Belt. Use a zip tie to secure the loop.



29. It may help to remove the Idler Top bracket so that the GT2 belt can loop around the idler pulley.

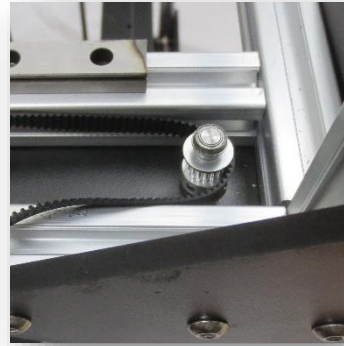

30. Loop the belt around the Y stepper motor pulley.



31. Loop the end of the belt through the other end of the Y-Belt. Pull the belt tight and use a zip tie to secure it in place. Trim any excess belt.

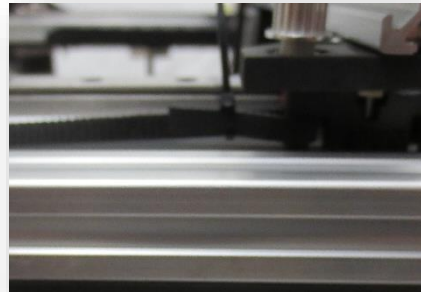

32. Loosen the two screws on the stepper motor and pull so that the belt tightens. Tighten the two screws when the belt is tight.



33. Repeat steps 28-32 for the other Y Belt.



34. Take a one-meter length of GT2 Belt and loop one end of the belt through one end of the extruder back plate. Secure it with a zip tie.

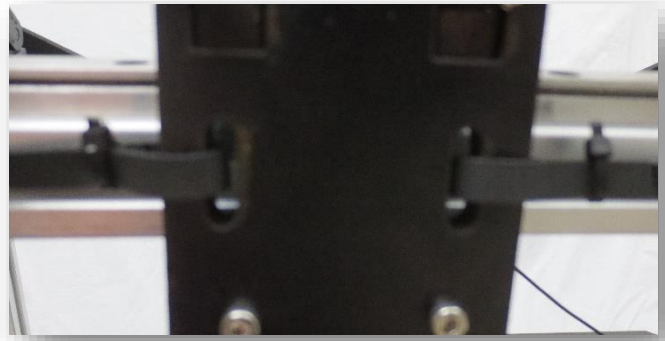

35. Loop around the stepper motor pulley.

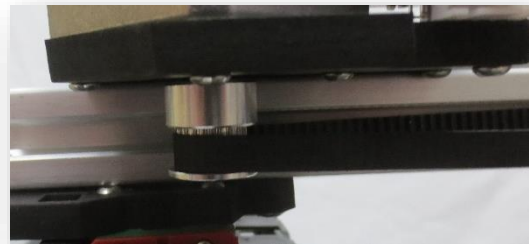

36. Loop around the idler pulley. Finish it off by looping through the other end of the extruder back plate. Use a zip tie to secure it in place and trim the excess.

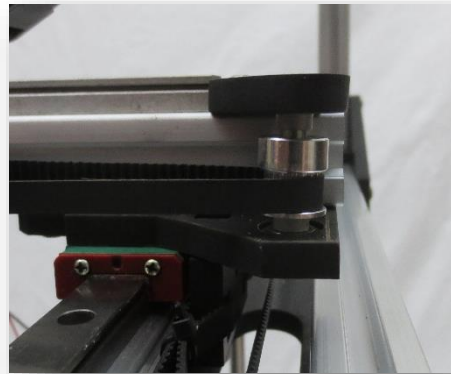

37. Loosen the two M5 screws and pull the motor so that the belt is tight. Tighten these back down when the belt is tight.

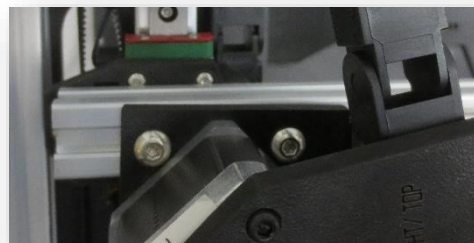

## 11) MOUNTING ELECTRONICS AND SPOOL MOUNT

In this section, the electronic case will be assembled and the electronics mounted. The spool mount will be assembled and mounted.

You will need:

Item ID	Quantity	Description
27	1	Power Supply
36	1	MKS Board
35	1	2004 LCD Screen
42	1	Spool Holder PVC
G	6	M3x12mm Screw
H	16	M3x16mm Screw
D	10	M3 Square Nut
P	4	Nylon Spacer
Z	2	M5x10mm Screw
Y	2	M5 T-nut
43	1	150mm M5 Threaded Rod
X	2	M5 Nylock
AD	1	Printed Estop Button
U	4	M4x10mm Screw
FT19	1	Electronics Box (MKS+PS)
FT20	1	Electronics Box Side (Power)
FT21	1	Electronics Box Side (USB)
FT22	1	Electronics Box (Honey Air vent)
FT24	1	Spool Holder (Circle)
FT28	1	Spool Holder (T-Hut)

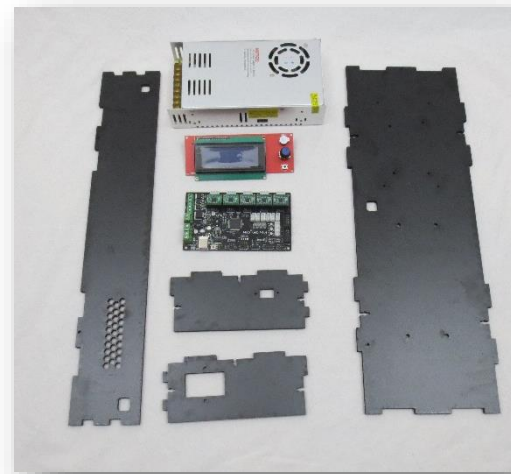

1. Lay the power supply face down, and FT19 on top of it. Line up the four M4 holes on the back of the power supply and secure it in place using four M4x10mm screws.

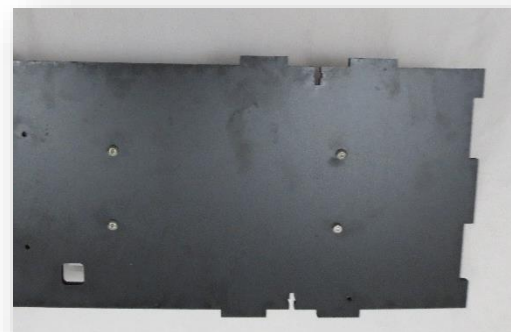

2. Place the MKS board next to the power supply and secure it in place using four M3x12mm screws and four M3 Nylocks.

Note: The power supply and the MKS board should be mounted facing each other.



3. Place FT19 onto the base plate, line up the slots with the tabs. Slide a M3 square nut into the slot and screw a M3x16mm screw in. It should look like the picture to the right with the base at the bottom and electronics facing the rear of the printer.

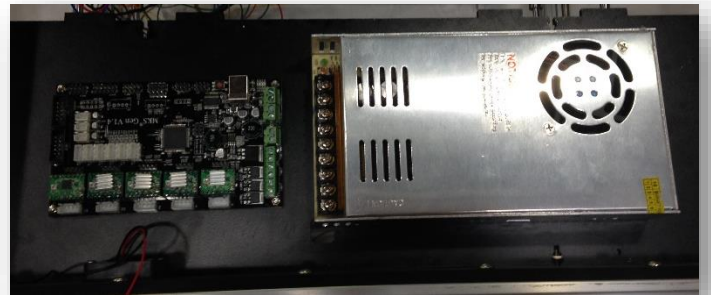

4. Place FT21 onto the left side, as viewing from the rear of the machine, and secure it in place using two M3x16mm screws and two M3 square nuts.



5. Place the power outlet onto FT20 and secure it in place using two M3x16mm screws and two M3 Nylocks.



6. Repeat the process from step 4 with on FT20 on the right side.



7. Take the USB cable mount plug and secure it onto FT21 using two M3x12mm screws. This is a good time to plug the other end into the MKS board before the top goes on.



8. Place FT22 on top and secure it in place using four M3x16mm screws and four M3 square nuts.

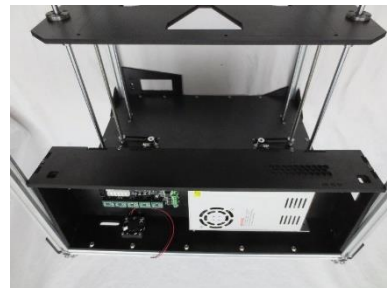

9. Take the LCD screen and remove the knob from the panel. Place the orange stop button through FT25 and then place the LCD screen into it. Place the knob back on and secure the panel in place using four M3x20mm screws, four nylon spacers, and four M3 Nylocks. **Place the four larger nylon spacers between the LCD screen and FT25.** Be careful not to over tighten the screws as this can damage the screen.



10. Take the Spool holder (FT24, FT28, and PVC Pipe) and sandwich the PVC pipe between the two pieces. Insert the M5 threaded rod through and secure the whole thing in place using two M5 Nylocks.



11. Mount the spool holder on the back right vertical member. Between the top bracket and the middle one.



## 12) ASSEMBLE AND MOUNT HEATED BED

In this section, the heated bed will be assembled and mounted to the bed platform.

You will need:

Item ID	Quantity	Description
25	1	300x300 Heated Bed(Old style)
26	1	300X300 Aluminum Bed Plate(Old Style)
25	1	White Aluminum Heated Bed(New Style)
45	1	Thermistor
56	1	14 AWG Wire
63	1	Braided Cover
39	1	Kapton Tape
O	6	Bed spring
I	6	M3x30mm Screw
M	6	M3 thumb Screw

You may want to look at the Full Wiring Diagram [HERE](#)

**Note: If you have the white aluminum heated bed follow the same steps below without the aluminum plate.**

1. Cut the red wire in half and strip  $\frac{1}{4}$  inch of each end. Solder on each wire to the heated bed.

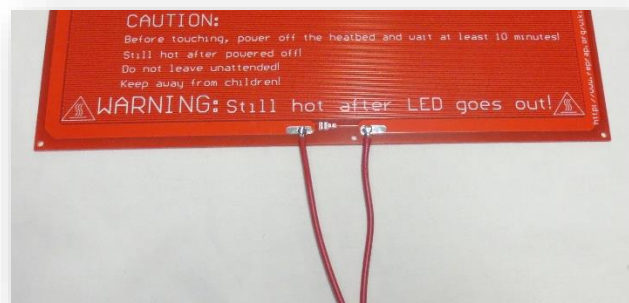
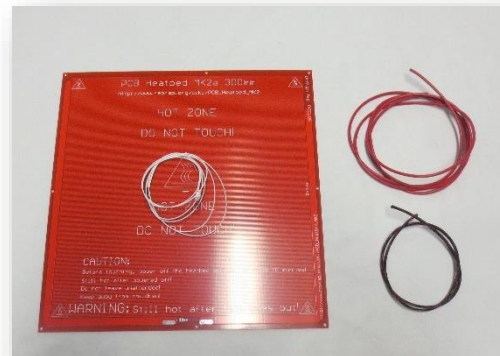

2. Fish the two red wires and the thermistor wire through the braided cover and secure them in place with the large heat shrink.

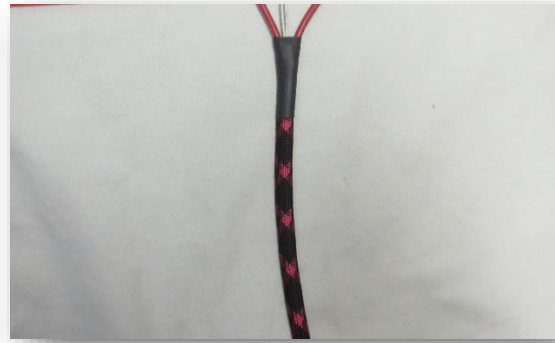

3. Secure the thermistor down using a few pieces of kapton tape.

Note: Add some kapton or electrical tape to the other side of the solder joints for the two power wires. This will help prevent a contact between the wires and the AL print bed.



4. Lay the bed over the bed platform, looping the wires down through one of the openings.



5. Secure each of the six hole locations with a M3x30mm screw, bed spring, and a M3 thumb screw.





### 13) WIRING

In this section, the wires will be run to all of the components.

1. Take a endstop cable and plug the 4 pin connector into the Y endstop.

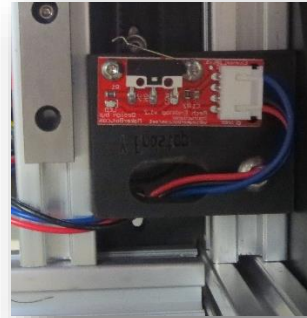

2. Take two 1 meter motor wires and plug the motor end into the two Y axis stepper motors.

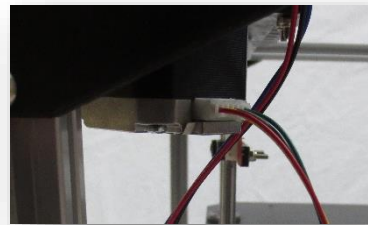

3. On each Y axis stepper motor, clip all four wires 300mm from the 4 pin board connector. Strip ¼ inch off each wire.
4. Combine the following two wires together:  
Insert them into the 4 pin green connector with the screws facing up.

As from looking from the front of the printer.

**Green (Right Motor)/Red (Left Motor)**  
**Gray (Right Motor)/Yellow (Left Motor)**  
**Yellow (Right Motor) /Gray (Left Motor)**  
**Red (Right Motor ) /Green (Left Motor )**

Take the 4 pin pigtail, and strip ¼ inch off the ends of each wire. Insert them into the other end of the 4 pin terminal as follows:

**Green, Yellow, Gray, Red.**

From Y motors	4 Pin Connector		To MKS Board
Red - Green	⊖		Green
Gray - Yellow	⊖		Yellow
Yellow - Gray	⊖		Gray
Green - Red	⊖		Red

5. Take a 2 Meter motor wire and plug the motor end of the cable into the X axis stepper motor.

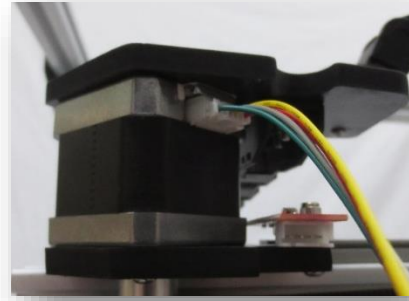

6. Take 4 pin connector and the 2 meter endstop cable (red, green, and black 24 awg wire), insert the 4 pin connector into the x axis limit switch. Looking at the bottom of the limit switch insert the four wires in the following order: **Red, Black, Empty Space and Green.**

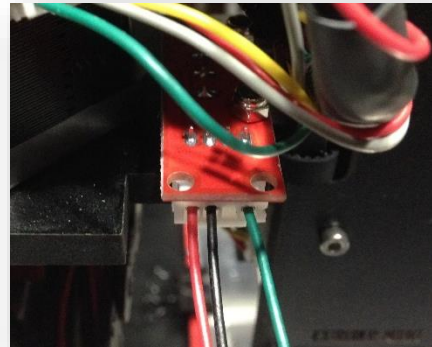

7. Take the last endstop cable and plug it into the Z axis endstop.

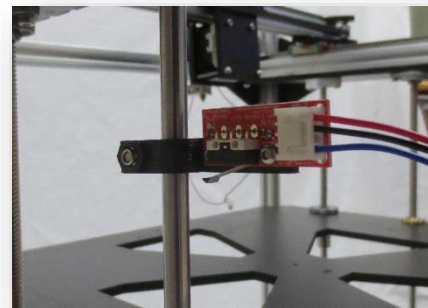

8. Take the 2M stepper motor cable and plug it into the extruder stepper motor.

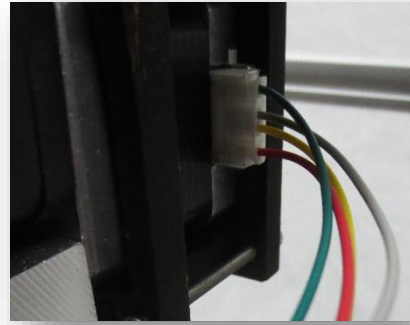

9. Take the 1.6 meter Red and Black 18 awg wires, 1.6 meter Red and Black 24 awg wire, and two 1.6 meter green 24 awg wire and bundle them together. Take some tape and bind one of the ends together. Take the braided wire cover and feed the bundle through. Use the heat shrink to bind the bundle together.

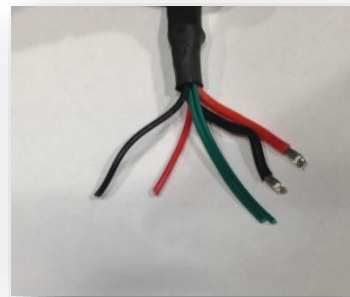

10. Prepare the hotend bundle by removing the connector from the board side of the extruder motor cable. This will help with feeding the bundle through the cable chain. Using electrical or kapton tape, tape the end of the bundle together. Make sure to tape and label the motor wire cable. This will be important when feeding through the second cable chain.

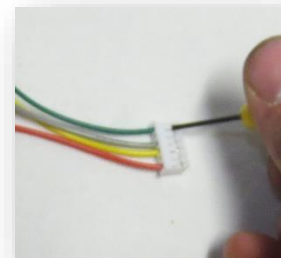

Remove the pin by inserting a small screw driver or pin and lifting the tab. Pull the wire out.

11. It helps to remove the chain from the mounts for feeding wires through it. Feed the wire bundle and the stepper motor cable from the extruder to the x axis motor.

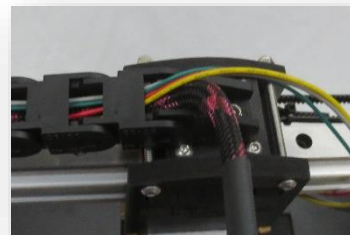

12. Snap both ends back in, making sure the wires are not pinched.

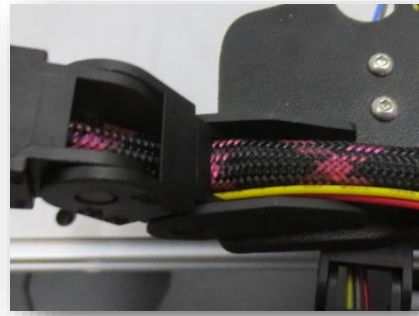

13. Cut the thermistor down to 5 inches and strip the ends of the wires. Do the same to the hotend fan wires. Take the white small 4 pin connector and solder the thermistor wires and fan wires in the following order: white, white, red, black. The orientation of the thermistor is not important but the fan wires are. Make sure to feed on heat shrink before soldering and then cover the solder with heat shrink.

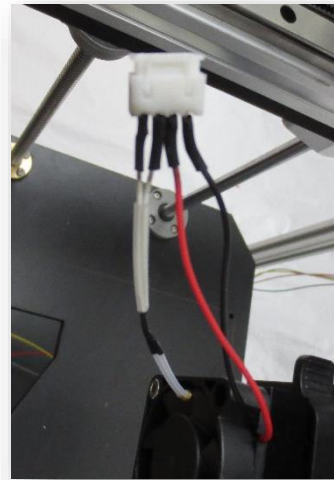

14. Insert the two green, red, and black 24 awg wires into the white connector in the following order (left to right). **Green, Green, Red, Black.** Note that the green wires should line up with the two thermistor wires. The red and black wires should line up with the red and black wires from the extruder fan.

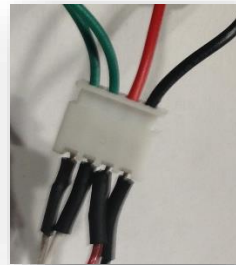

15. Take the heater core and cut it down to 5 inches. Strip off  $\frac{1}{4}$  inch of each wire and insert them into the white (H shaped) wire connector. In the other end of the H connector should be the two 18 awg wires from the hotend bundle. The connector might vary from the one pictured.



16. Remove the two top screws on the hotend and insert two small cable clamps (one on each). The left one should have all the wiring in it and the right one should be empty. It is used as a filament guide later.

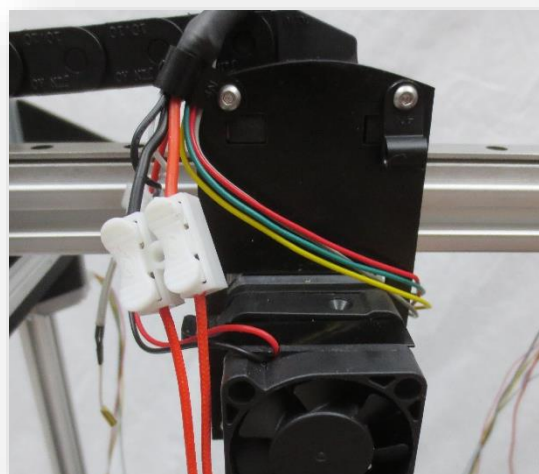

17. Insert the heater core and the thermistor into the Al heater block on the hotend. Secure them in place using the three set screws. Make sure not to tighten the thermistor down too much as this will damage the thermistor.

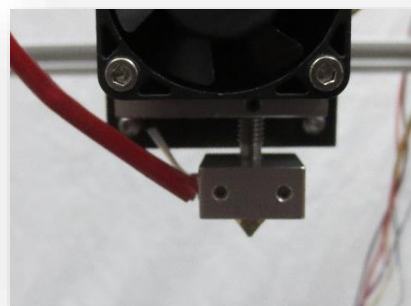

- Using a small cable clip, insert the hotend wire bundle and the extruder motor wire. Lock it down using a M3x12mm screw and a M3 Nylock.

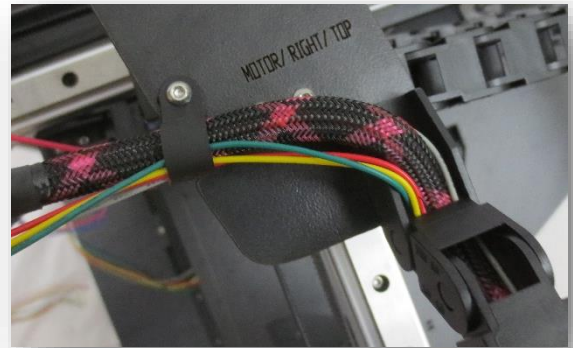

- Remove the board connector from the X axis motor cable and the X axis endstop. Make sure to tape and label each bundle. Take the X axis stepper cable, X axis endstop cable, hotend bundle, and the extruder stepper cable and tape the ends of them together.

- Feed the bundle made in step 18 through the Y axis cable chain. It will help to remove the chain when feeding wires through.

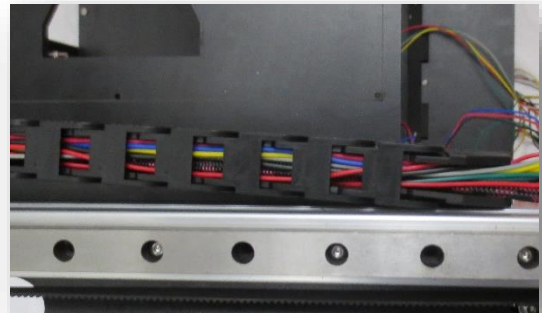

- Pull the wires tight and take the time to organize them. This will be important during printing, so the cable will not snag on anything.

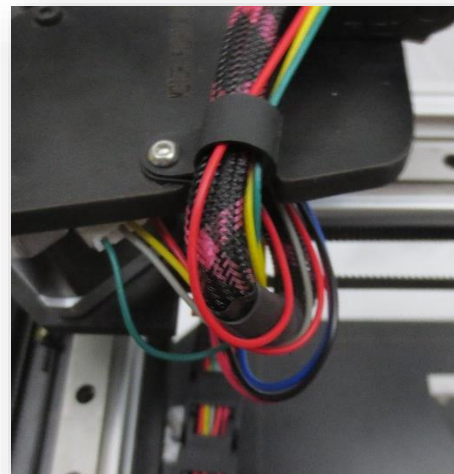
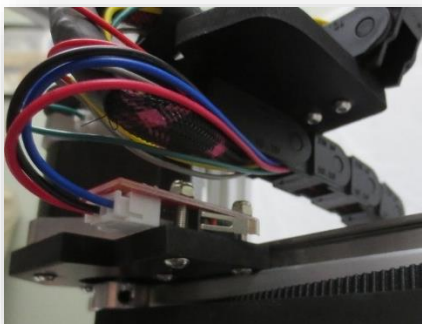

22. Insert the cables back into their respective board connector.

23. Take one of the 1M motor connectors and cut it about 12 inches from the 6 pin connector (motor end). Take a motor cable (without board connector) and combine the similar colored wires.

24. Take the green four terminal connectors, insert the wires in the following order:  
**Green, Gray, Yellow, and Red**  
 Take the remaining motor cable (with board connector), and strip ¼ inch off the ends of each wire. Insert them into the other end of the 4 pin terminal as follows: **Green, Gray, Yellow and Red**

25. Plug in the two motor connectors into the Z stepper motors.

**Motor Wire: Green, Yellow, Gray, Red**

**Endstop: Blue, Black, Red**

From Z motors	4 Pin Connector		To MKS Board
Green	⊖	⊖	Green
Gray	⊖	⊖	Gray
Yellow	⊖	⊖	Yellow
Red	⊖	⊖	Red

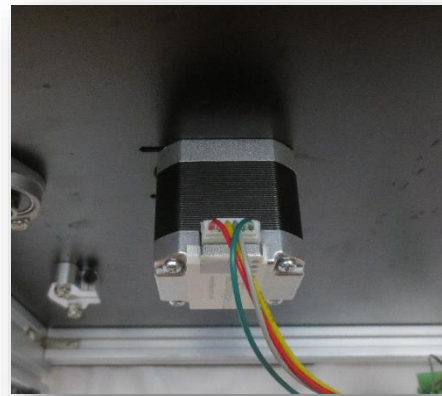

26. Use kapton tape to secure the connector to the base of the machine.

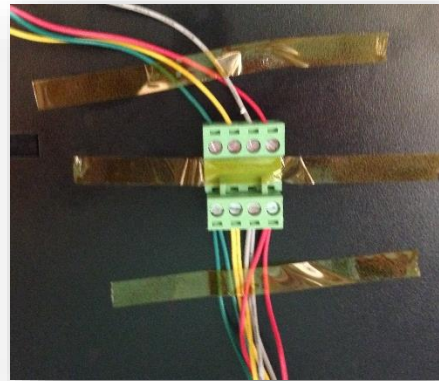

27. Cut a two-inch piece of the black 14 awg wire and strip ¼ inch off each end. Strip ¼ inch off the red, black, and green 14 awg wires too. Solder (or use up spade connectors if you have them) the green wire to the top connector (pin 1) of the power outlet. The red wire goes on the pin 2. The two-inch black jumper goes from pin 3-4 and finally the black 14 awg wire connects to pin 5.

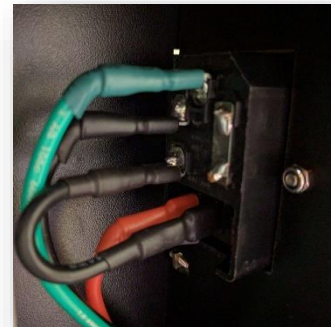

28. On the front of the power outlet, remove the fuse panel. Insert one of the fuses into the fuse slot and the second fuse into the spare slot.



Spare Fuse



29. Run the red, black, and green wires to the power supply and trim them so they run nicely to the lower three terminals. Strip  $\frac{1}{4}$  inch off the ends of the wires. Loosen the terminals using a screw driver. Insert the wires to the right of the screw. That way when the screw is tightened down, it pulls the wire in tight.

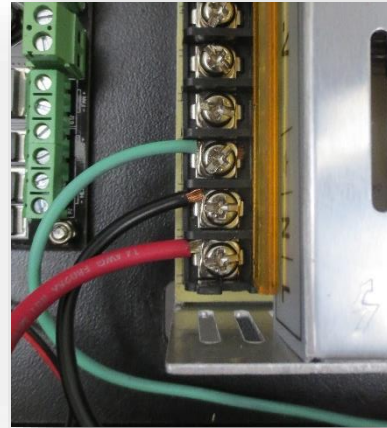

30. Take the red and black 14 awg wires and cut two 5 inch lengths of each. Strip  $\frac{1}{4}$  inch off each end. Connect the red wires to the positive terminals on the power supply (there are three positive and negative terminals and each wire should have its own). Do the same for the black wires to the negative terminals.

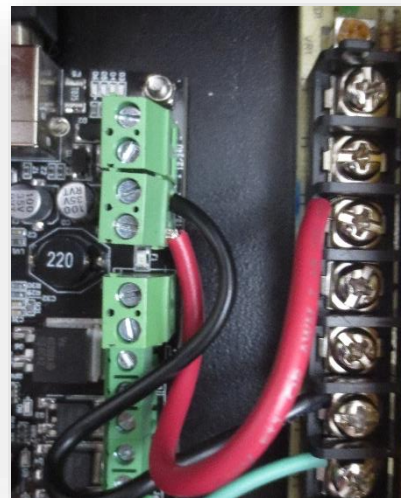

31. Connect the power to the board by loosening the screw on the terminal (on the board) and inserting the stripped wire. The order is as follows (from right to left): Black, Red, Black, Red. Connecting this wrong will burn out the board.

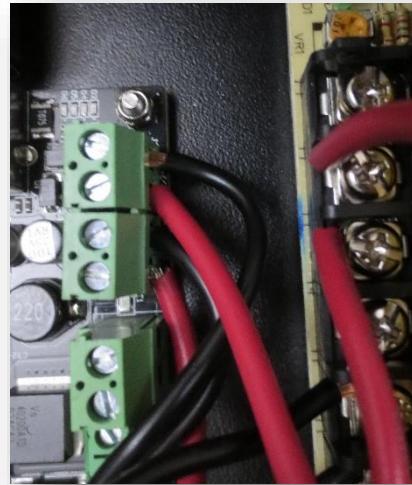

32. Cut and strip the two wires from the electrical box fan. Strip the two wires from the hotend fan. Insert these wires into the remaining positive and negative terminal. If there is ever a need for access to 12v, use these terminals.

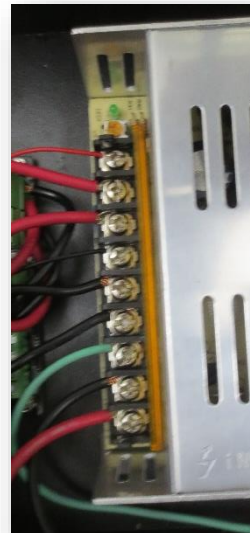

33. Plug in the four motor cables into the MKS board. The board is labeled with X Y Z E plug the cables into the corresponding holes.

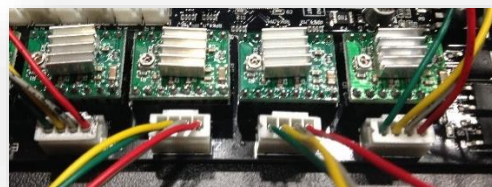

34. Plug in the three limit switches into the board.  
From right to left it's Z min, Y min, X min.

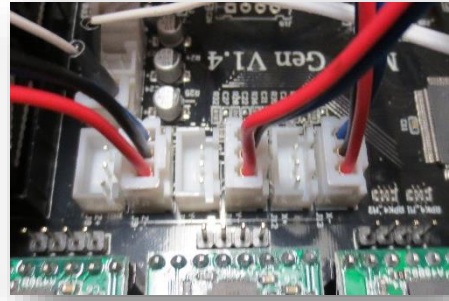

35. Plug in the two thermistor wires into the board.  
The middle is the heated bed and the bottom is the hotend thermistor.

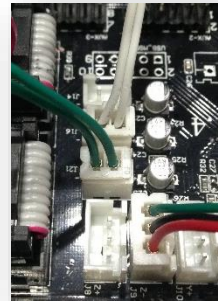

36. Insert the heatbed wires and the hotend heater wires into the board. The color orientation of these two do not matter.

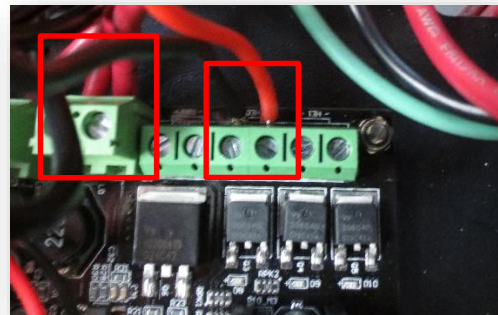

37. Add the heatsinks to the five stepper motor drivers. Peel off the paper on the bottom and stick them on top of the main chip of the driver.

**Power should be off to the machine for this step!!**

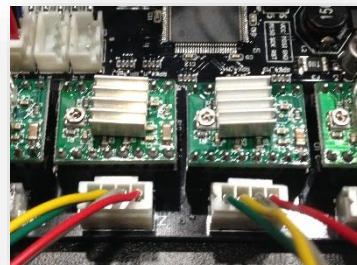

## TESTING AND CALIBRATION

Congratulations on successfully assembling your Folger Tech FT-5 3D Printer Kit! Now that it is built, it's time to verify that all the components are working properly. This will require a computer and the USB cable that came with the printer.

**\*\*\* Left and right as viewed from the front \*\*\***

### FT-5 Wiring Schematic - MKS Gen 1.4 Controller Board

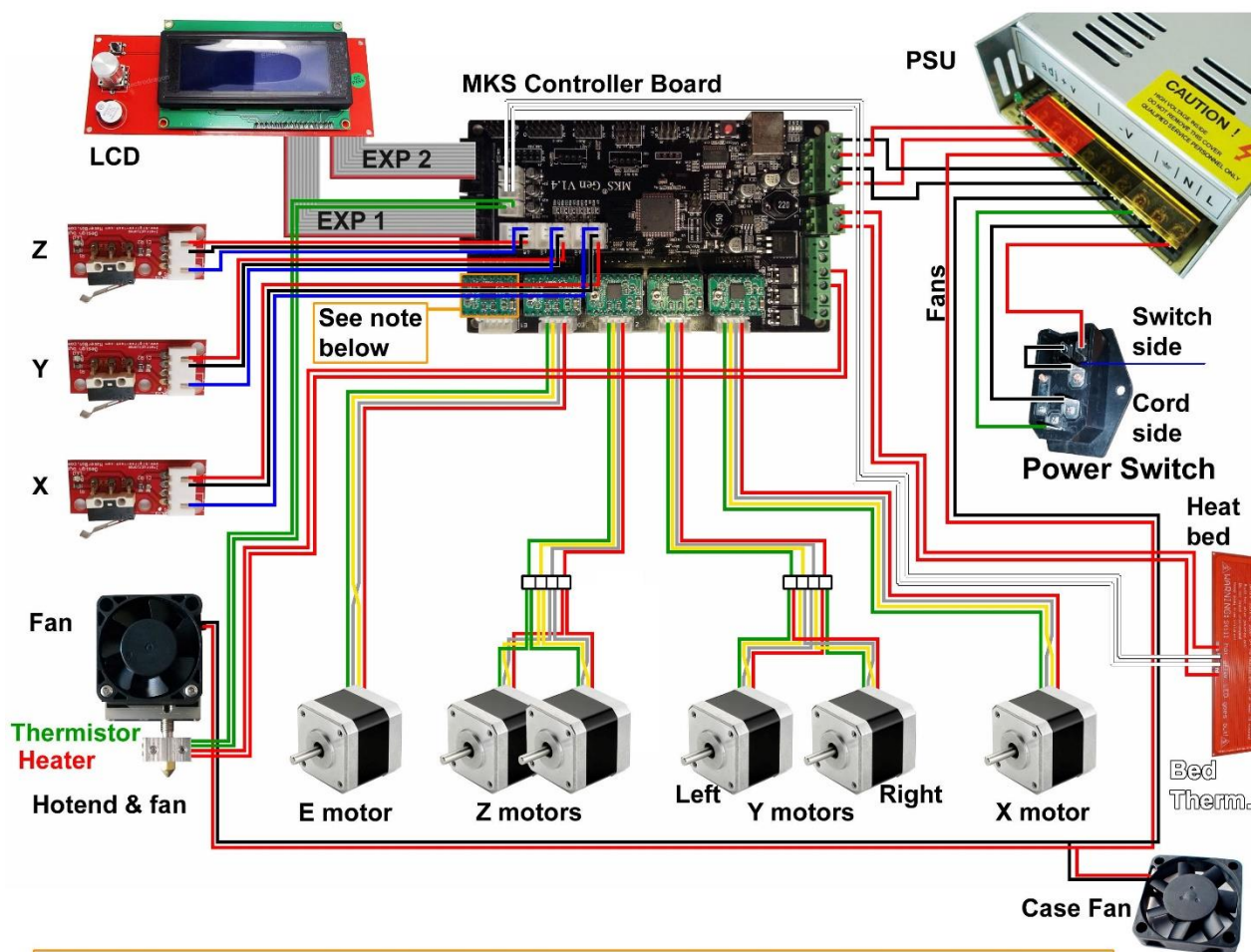

**Note:** Unless you are using dual (2) extruders, remove this stepper driver and its jumpers - they are not needed for single extruder use. Save them for a backup.

**Note 2:** Please pay special attention to wire orientations for the Y motors! It is very important that they be wired as shown for proper movement.

## ELECTRONICS CHECK LIST

The goal of this section is to make sure all of the electronics are plugged in correctly. It is important that you follow these steps and do not power up the printer before being instructed to do so.

1. The power coming into the board should be Black, Red, Black, Red for the 2 big green plugs on the MKS board.



2. The thermistor wires should be plugged into the 1<sup>st</sup> and 2<sup>rd</sup> connector. The top one should be the hot end and the bottom one should be the heated bed.

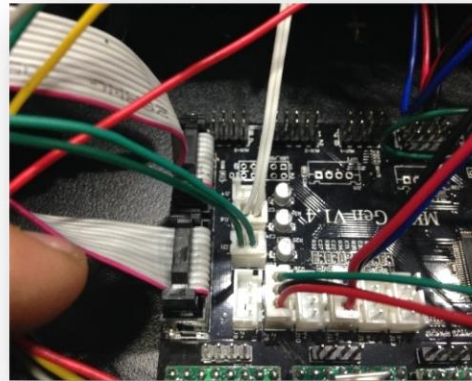

3. The endstops connectors should be in the following order:  
X-Min, None, Y-Min, None, Z-Min, None



4. All of the stepper drivers should be pointing to the left (trim pot facing away from the power input plugs).

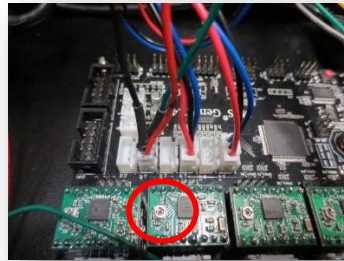

5. Verify that the fuse (250V 3A) has been inserted into the power outlet.



## SOFTWARE

The following software is used to test and run a Folger Tech FT-5 3D Printer.

- **Arduino** - Arduino is an open source hardware package that is attached to the underside of the base and is used to control the printer. The firmware running on Arduino is written in the Arduino programming language. This firmware is already loaded onto the printer and ready to go. We suggest you use version 1.6.5 or 1.6.7. <http://www.arduino.cc/en/main/software>
- **Pronterface** - Pronterface is used to test the components of the printer and run basic functions. It has a graphical user interface (gui) that controls the printer and allows the user to send individual g-code files to the printer. <http://www.pronterface.com/>
- **Cura** - Cura is the slicing software that turns the digital object, which is the stl file 3D model, into the g-code the printer can understand. <https://ultimaker.com/en/products/cura-software>
- **Firmware** - The printer will need firmware to operate. You can find it here: [Firmware Download](#)

## CONNECT TO THE PRINTER & LOADING FIRMWARE

Plug in the USB cable into the USB slot located on the right of the machine.



Download the firmware and extract it to a folder where you can find it. Open the Marlin.ino firmware using the Arduino IDE, press open and navigate to where you extracted the firmware a minute ago. Press the compile and load button and wait for it to say **Done Uploading**. Leave this open because we will be coming back to calibrate the printer.

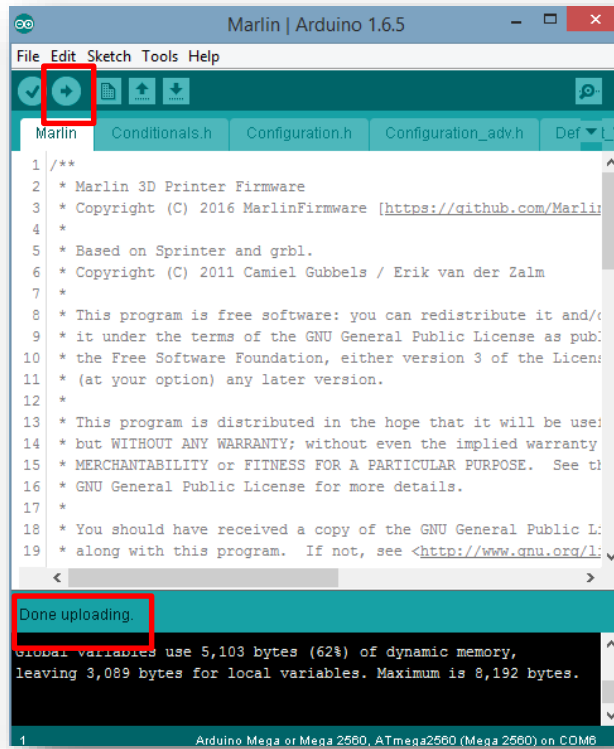

## VERIFY THE ENDSTOPS

Now that the printer is connected to the computer and it has recognized Arduino it's time to open the Pronterface software. Open the Pronterface folder on the SD card, and select the Pronterface icon shown in the image below. We suggest copying the entire Pronterface folder onto your computer for later use.

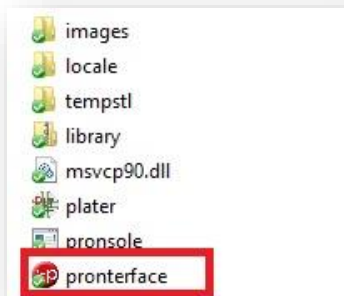



Select the "COM" port that is associated with the printer (this will depend on which one your computer assigns). Then click the "Connect" button to the right of the port pulldown. If the computer is connected to the printer correctly, then you should see "the printer is now online" on the right.

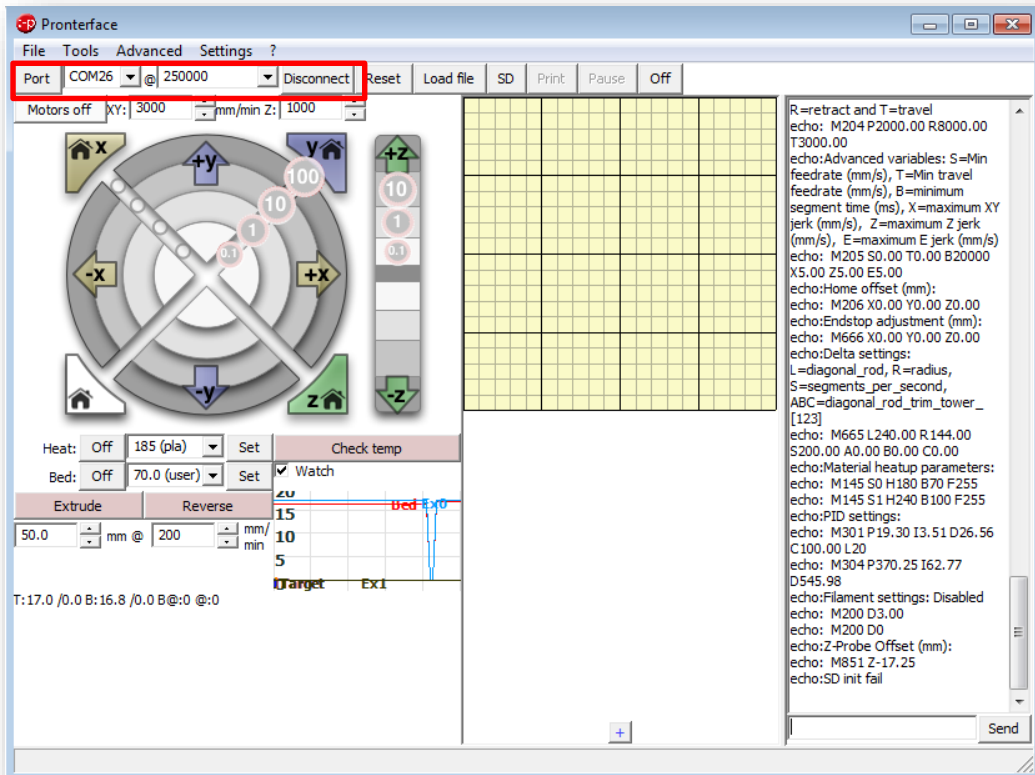

Manually move the gantry with your hands so that it is not touching the X and Y endstops. Turn the Acme threaded rods with your hands so the Z endstop is not engaged. In the bottom right of the screen in Pronterface, type in "m119" and click send. This code will tell the printer to send back the status of the end stops.

Each endstop status should return as "open," which will appear in the text column on the right side of the screen. Now, manually move the gantry until the X endstops make a click noise and the led on the endstops turns red. Send the "m119" command again in the bottom right corner. Verify the X endstop has triggered. Repeat this for the Y and Z endstop. It helps to do them individually in case they have been wired wrong.

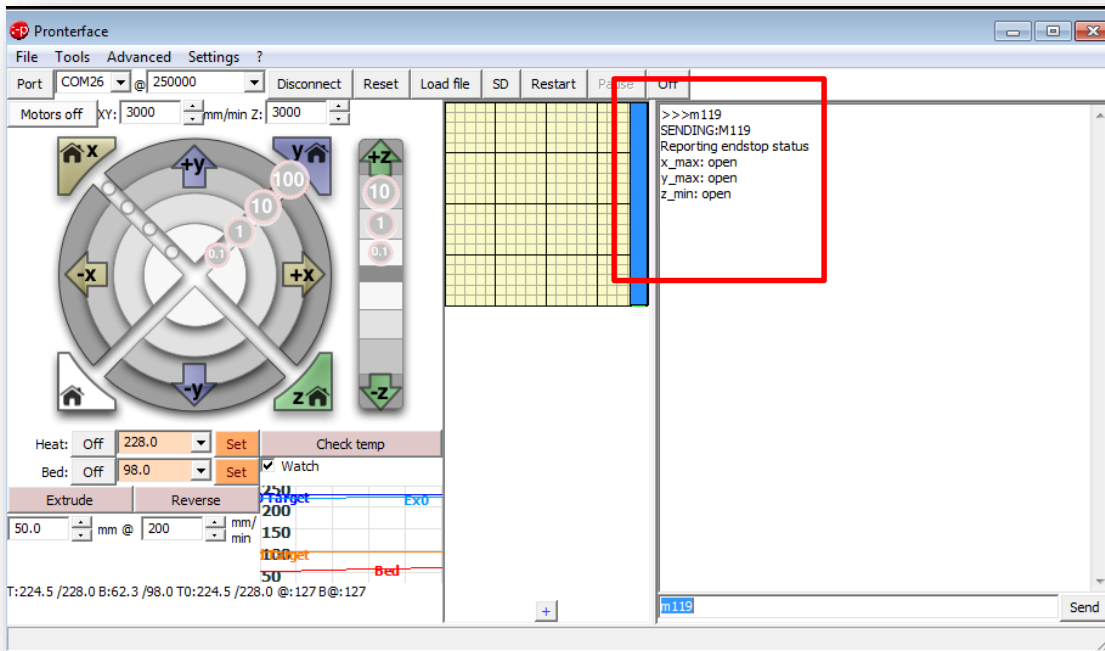

## VERIFY MOTOR DIRECTION AND HOMING

To verify that the motors are wired correctly, click on the home button on Pronterface. This will tell the gantry to move towards the home position. **Note that at any time during this step be ready to turn off the printer in case the gantry moves in the wrong direction during this process.**

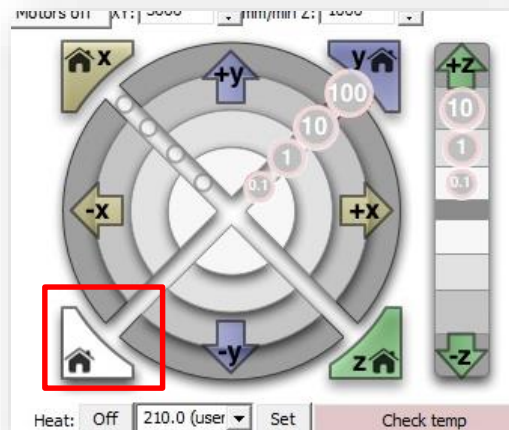

## ADJUSTING Z HEIGHT

The Marlin Firmware comes with a z height that will work with all machines. This value can be fine-tuned to maximize z height.

Open Marlin.ino and click on the Configuration.h tab.

Scroll down until you find the **Travel limits after homing** then #define Z\_MAX\_POS. This is the value that will be adjusted to each printer. This is the value that is adjusted for the z height.

```
// Travel limits after homing
#define X_MAX_POS 300
#define X_MIN_POS 0
#define Y_MAX_POS 300
#define Y_MIN_POS 0
#define Z_MAX_POS 400
#define Z_MIN_POS 0
```

## VERIFY THE HOT END TEMPERATURE

Use Pronterface to verify that the hot end is working properly. Set the “heat” temperature to 230°C and click the set button. Watch the graph to make sure the temperature of the hot end is heating up and holds steady around 230°C. If the bed temp is rising, then they are plugged in backwards. Set the bed temp to 100 and click the set button.

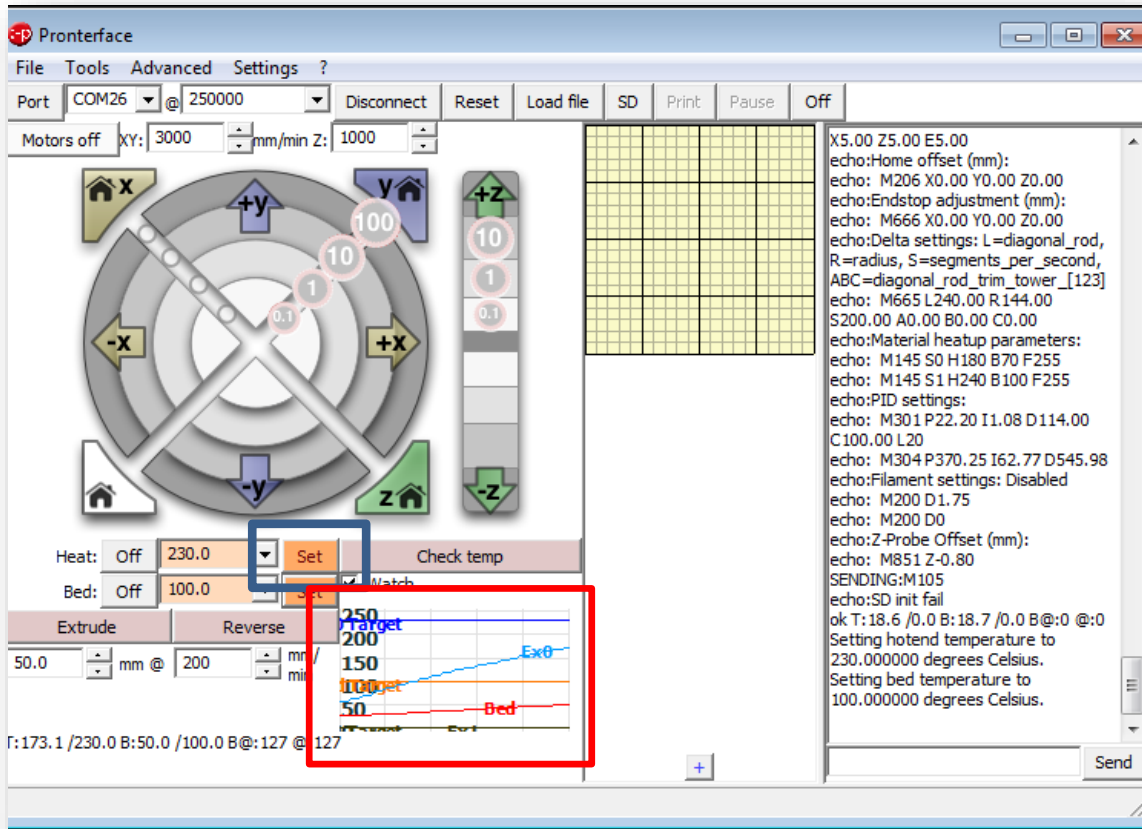

Once the printer bed has reached temp and maintained it for a few minutes, press the off button. **Before turning off the hot end, proceed to the next step “Verify the Extruder”.**

## VERIFY THE EXTRUDER

With the hot end at 230°C, click on the “Extrude” button on Pronterface. The extruder will not run if the hot end is under 170°C. Now the drive gear should turn in a clockwise direction. Turn off the hot end by clicking the “Off” button next to “Heat” on Pronterface.

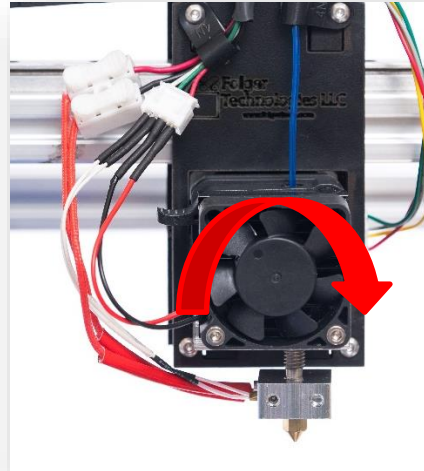
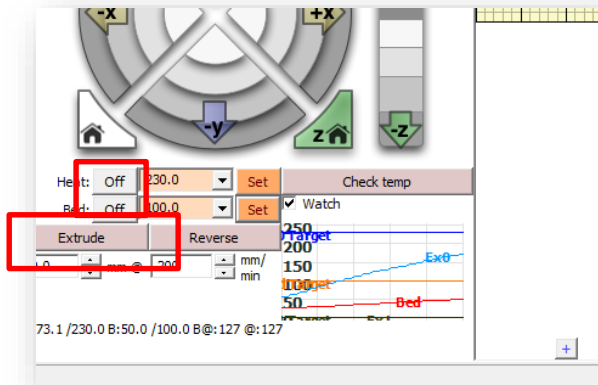

## SOFTWARE PARAMETER SETUP

Folger Tech recommends using Cura Software as the G-code generation software. G-code is a commonly used numerical control programming language used to control the position, speed, and path of the 3D printer. **Please use version 15.xx as version 2.xx does not work.**

**Note:** While Folger Tech recommends using Cura for slicing and G-code generation, other slicing software can be used. The printer parameters detailed below are a recommended for optimum performance of a Folger Tech printer, which can be used for other software.

The printer setup for Cura will only need to be completed once.

## SETTING UP A PRINTER PROFILE IN CURA

1. Download and install Cura at <https://software.ultimaker.com/>
2. Launch the Cura program from your computer's start menu or desktop icon
3. To setup your printer, select **Machine > Add new Machine**

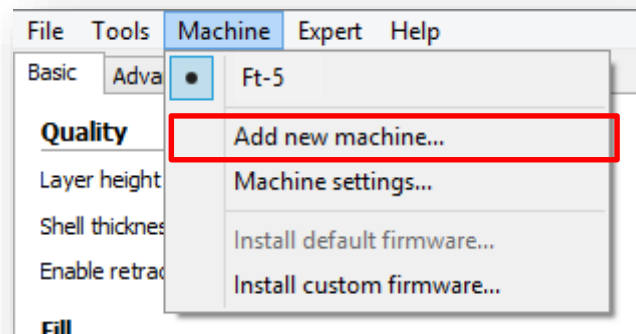

4. Click **Next** on the Configuration Wizard.

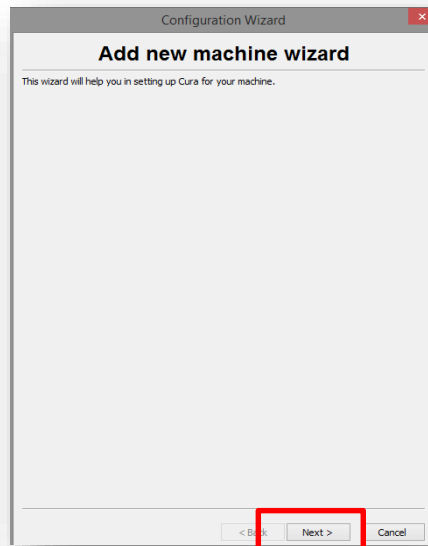

5. Under “Select your machine,” choose **Other (Ex: RepRap, MakerBot, Witbox)**. Then click **Next**.

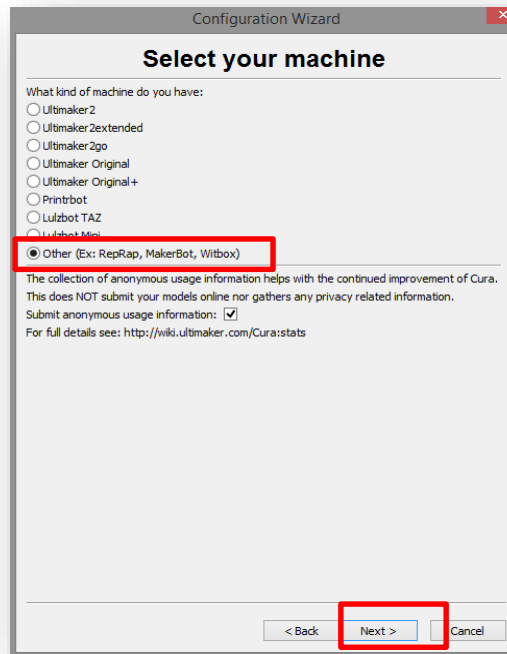

6. Under “Other machine information,” select **Custom** and click **Next**.

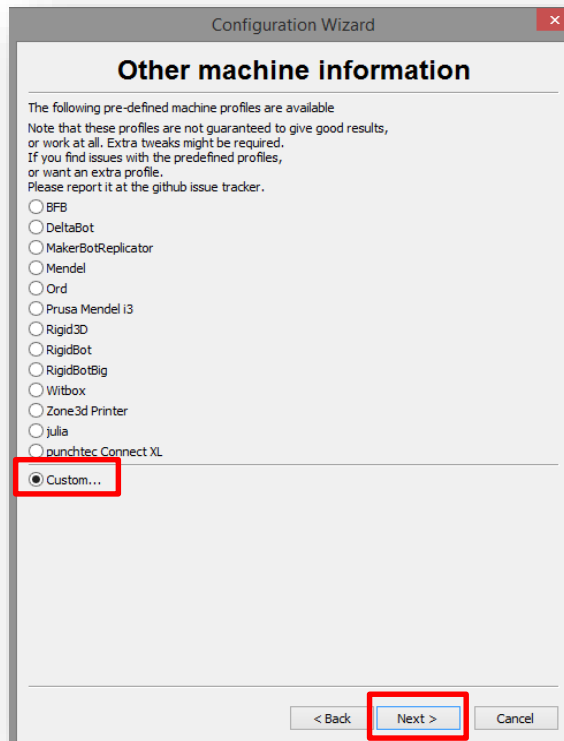



Input the following values into the RepRap custom settings. Machine height was calculated in a previous section.

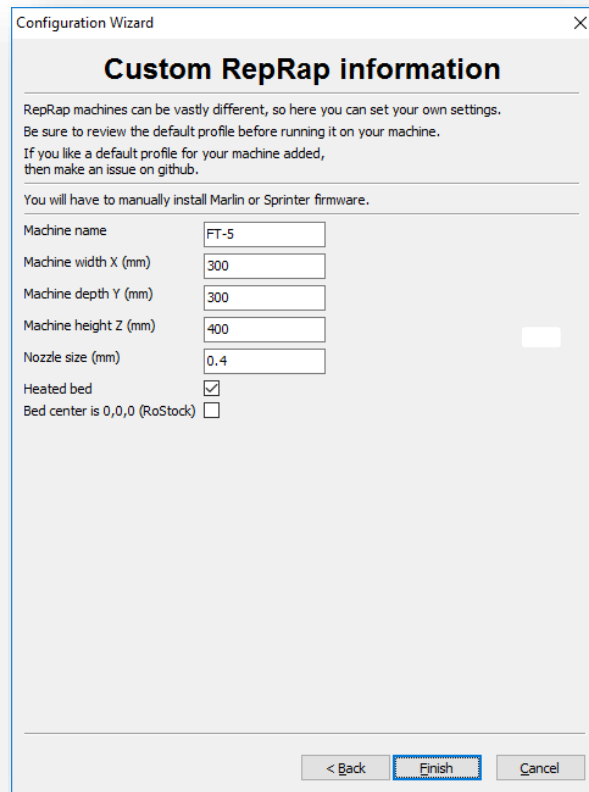

The image shows a 'Configuration Wizard' dialog box with the title 'Custom RepRap information'. It contains the following text and fields:

RepRap machines can be vastly different, so here you can set your own settings.  
Be sure to review the default profile before running it on your machine.  
If you like a default profile for your machine added, then make an issue on github.

You will have to manually install Marlin or Sprinter firmware.

Machine name: FT-5  
Machine width X (mm): 300  
Machine depth Y (mm): 300  
Machine height Z (mm): 400  
Nozzle size (mm): 0.4  
Heated bed:   
Bed center is 0,0,0 (RoStock):

At the bottom, there are three buttons: '< Back', 'Finish', and 'Cancel'. The 'Finish' button is highlighted with a blue border.

## PRINTING SETTINGS

Printing settings determine the characteristics for an individual print. These settings include: print speed, fill density, shell thickness, layer height, and other advanced settings. This section should be used as a guide to the different settings that may need to be changed, and which settings should remain constant depending on your desired results.

## PRINTING SETTING DEFINITIONS

### Basic Settings

The parameters that are frequently adjusted to obtain the desired results for an individual part are found under the Basic Setting tab in Cura. The figure below shows the typical Basic tab settings for most prints. A detailed explanation of each parameter can be found below in the figure.

The screenshot shows the Cura printing settings interface with the 'Basic' tab selected. The settings are organized into several sections:

- Quality**
  - Layer height (mm): 0.2
  - Shell thickness (mm): 0.8
  - Enable retraction:
- Fill**
  - Bottom/Top thickness (mm): 0.6
  - Fill Density (%): 20
- Speed and Temperature**
  - Print speed (mm/s): 50
  - Printing temperature (C): 230
  - Bed temperature (C): 100
- Support**
  - Support type: None
  - Platform adhesion type: None
- Filament**
  - Diameter (mm): 1.75
  - Flow (%): 100.0

## Quality

- **Layer Height (mm):** This describes the Z distance between each layer. For a 0.4 mm nozzle, the average quality can be achieved with a layer height of 0.2 mm. Average quality is sufficient for most prints except for items with fine details. If a higher resolution is desired, the layer height setting can be changed to 0.15 mm or 0.1 mm.
- **Shell Thickness (mm):** This describes the thickness of the outer shell of a printed part. This value must be a multiple of the nozzle size. For example, when using a 0.4 mm nozzle a 0.8 mm shell thickness is two nozzle widths.
- **Enable Retraction:** This setting allows the extruder to retract the filament when it is traveling between points during a print. Retracting the filament will prevent the nozzle from leaving a residue as it travels.

## Fill

- **Bottom/Top Thickness (mm):** This describes the thickness of the solid bottom and top layers of a part. This value must be a multiple of the layer height. For example, a part with a layer height of 0.2 mm will have 3 solid bottom and top layers when the input is 0.6 mm for this parameter.
- **Fill Density (%):** This describes the amount of infill that will be printed in a part. Typically, an infill of 20% is sufficient internal support to make a strong part. Increasing the infill to 70% will make an almost solid part. Click on the “...” button to show the Expert config window. In this window, the top and bottom layers can be turned off. For example, a vase can be made by turning the solid infill top to off and setting the fill density to 0%.

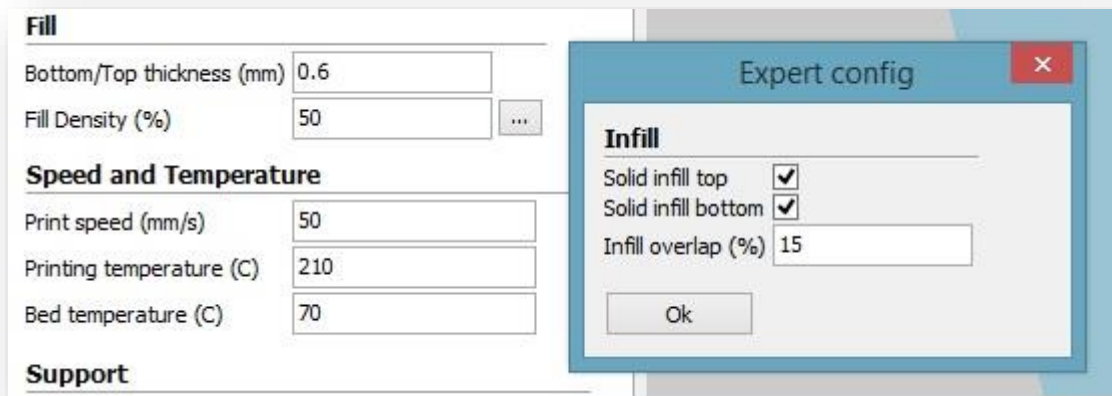

## Speed and Temperature

- **Printing speed (mm/s):** This describes the nozzle speed while printing.
- **Printing temperature (°C):** This describes the temperature of the hotend while printing. This value can be adjusted depending on the material being used. PLA should be set between 200 °C - 210 °C. ABS should be set between 230 °C - 240°C.
- **Bed Temperature (°C):** This is the temperature of the heated bed. ABS should be set too 100 °C and PLA should be set to 70 °C. Although PLA can be printed without the heated bed turned on.

## Support

- **Support type:** Support material is used when a model's geometry exceeds 60 degrees from the vertical for a part feature. There are three support type options: 1) None, which should be used when there are no features that exceed 60 degrees.
- **Touching buildplate,** which will add support material everywhere that a feature exceeds the 60-degree requirement as long as the structure overhangs the printer bed and not another section of the part, and 3) Everywhere, which will add support material to all features that exceed the 60-degree requirement, including overhangs that are over another section of the part. Clicking on the "..." button will bring up the Expert config window where additional features can be edited.

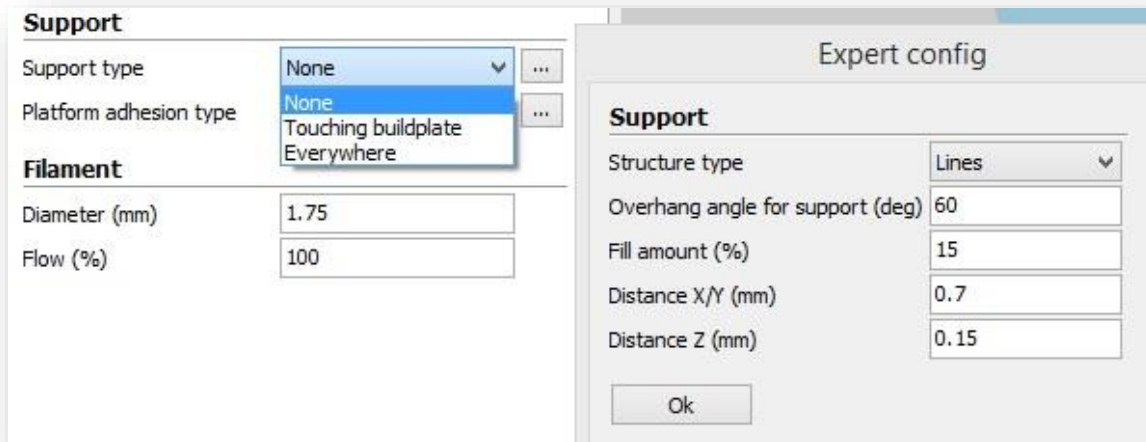

- **Platform adhesion type:** The platform adhesion setting is used to prevent the part from warping or peeling off the printer bed. If the printer bed is properly prepared using blue painters tape, the platform adhesion parameter should not be needed using PLA filament. There are two types of platform adhesion: 1) Brim, which is a flat single layer that extends past the footprint of the part to extend the adhesion area, and 2) Raft, which is a support structure under a print that helps secure it to the bed. A skirt is the initial pass that outlines a part to prepare the hot end for printing.

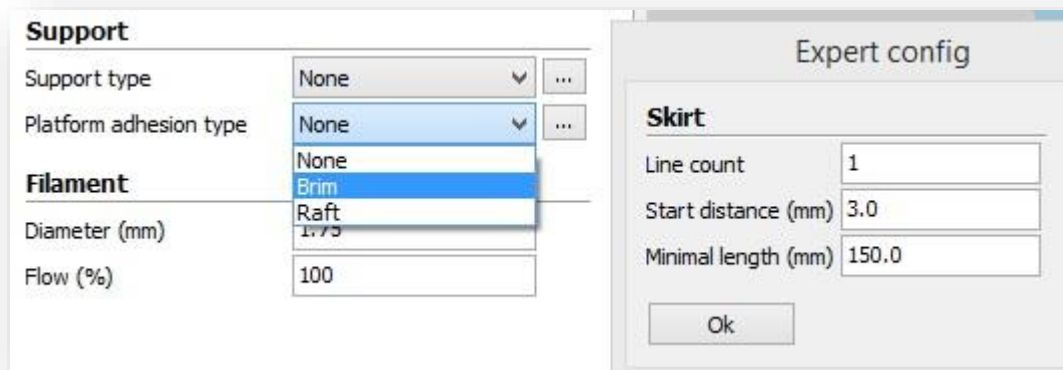

## Filament

- **Diameter (mm):** This describes the diameter of the filament being used. This value should be adjusted to the standard Folger Tech filament of 1.75 mm.
- **Flow (%):** This describes the amount of filament being pushed through the nozzle. This value can be adjusted to optimize the quality of the print. A typical value is between 90-100 % for your FT-5 printer. If excessive plastic is being extruded, reduce this value by 5%.

## Advanced Settings Defined

The Advanced tab parameters are printer specific and most will only need to be adjusted once. The figure below shows the typical advanced tab settings for your FT-5 printer. A detailed explanation of each parameter can be found below in the figure.

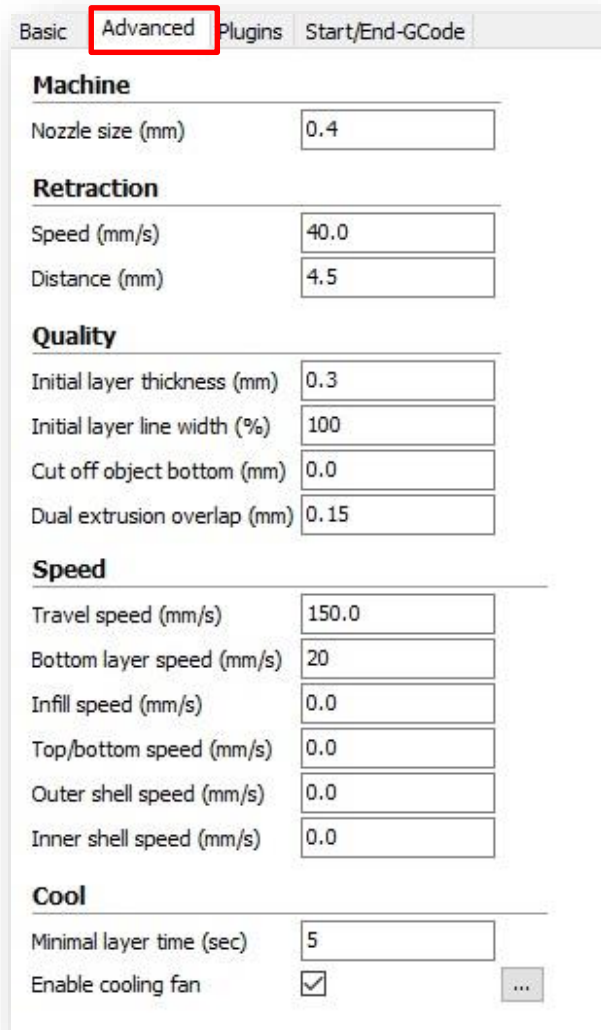

Tab	Basic	Advanced	Plugins	Start/End-GCode
<b>Machine</b>				
Nozzle size (mm)		0.4		
<b>Retraction</b>				
Speed (mm/s)		40.0		
Distance (mm)		4.5		
<b>Quality</b>				
Initial layer thickness (mm)		0.3		
Initial layer line width (%)		100		
Cut off object bottom (mm)		0.0		
Dual extrusion overlap (mm)		0.15		
<b>Speed</b>				
Travel speed (mm/s)		150.0		
Bottom layer speed (mm/s)		20		
Infill speed (mm/s)		0.0		
Top/bottom speed (mm/s)		0.0		
Outer shell speed (mm/s)		0.0		
Inner shell speed (mm/s)		0.0		
<b>Cool</b>				
Minimal layer time (sec)		5		
Enable cooling fan		<input checked="" type="checkbox"/>		...

## Machine

- **Nozzle size:** The size of the nozzle being used.

## Retraction

- **Speed (mm/s):** The speed at which the filament is retracted.
- **Distance (mm):** The distance the filament is retracted. This value can be raised if there is excessive residue during printing.

## Quality (Only applicable parameters discussed)

- **Initial layer thickness (mm):** The distance between the printer bed and the nozzle for the initial printed layer.

## Speed (Only applicable parameters discussed)

- **Travel speed (mm/s):** The speed at which the hot end moves when it's not extruding filament.
- **Bottom layer speed (mm/s):** The speed at which the hot end moves when printing the first layer. This value is typically set lower than the normal print speed to ensure adhesion of the first layer.

## Individual Part Settings (located at the lower right of the printer window)

- **Rotate** - This function allows the part to be rotated inside the printer's workable volume. To rotate a model, click on the rotate function in the lower left corner. Select the axis of rotation by selecting and holding the desired circle around the part. Drag the circle to change the orientation of the part.

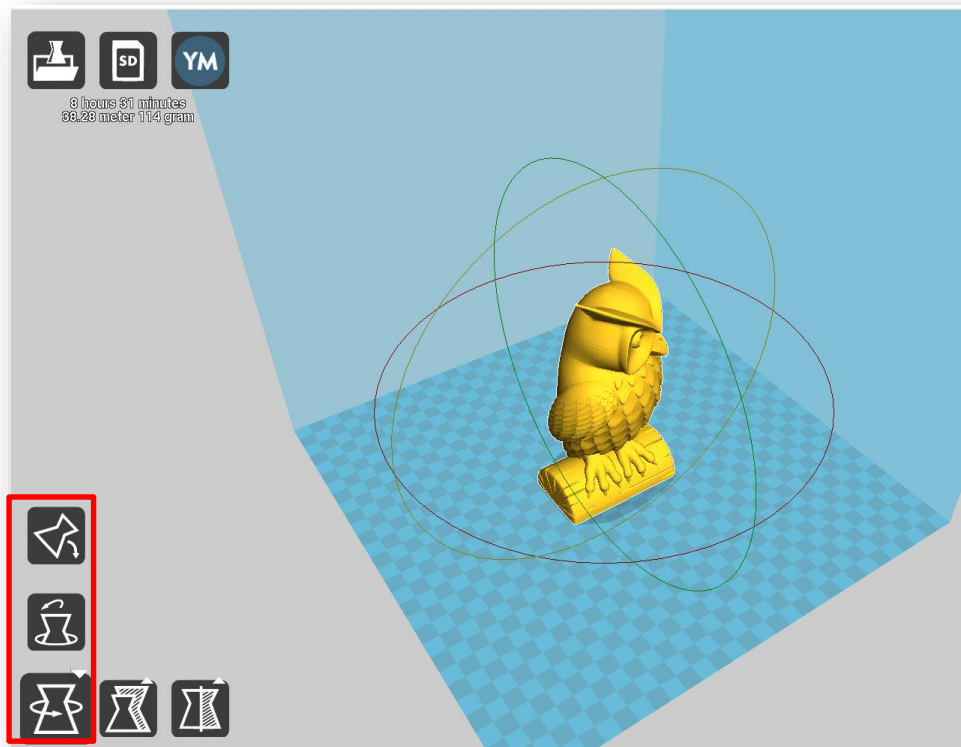

**Scale** – The scale function adjusts the dimensions of the part. Click on the scale icon in the lower left corner. The scale can be adjusted by a percentage or a dimension.

**Note:** Cura interprets all dimensions in millimeters. If the model was made using inches it will appear very small in the Cura window. Simply select the part and uniformly scale it by 25.4 to restore the part to its correct size.

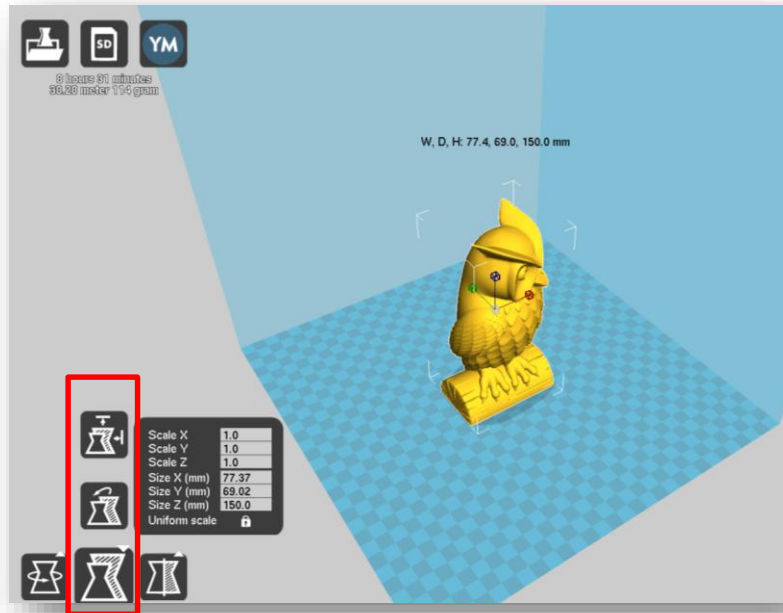

- **Mirror** – This function allows you to mirror the part about an axis. Click on the mirror icon in the lower left corner to activate this function. Select the desired axis to mirror part about.

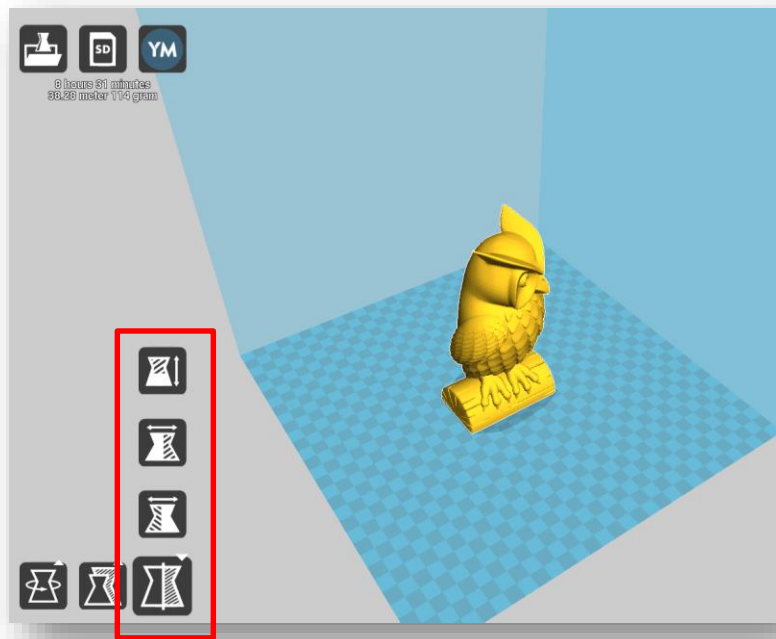

## GENERATING G-CODE USING CURA

This section details the baseline parameters to use for generating G-code in the Cura software. G-code is the machine language that the control the printer motors and heater. Individual objects may require changing some of the parameters discussed in the previous sections to obtain the desired quality and speed.

### STEP-BY-STEP PROCESS

1. Verify that FT-5 is selected under the Machine tab.

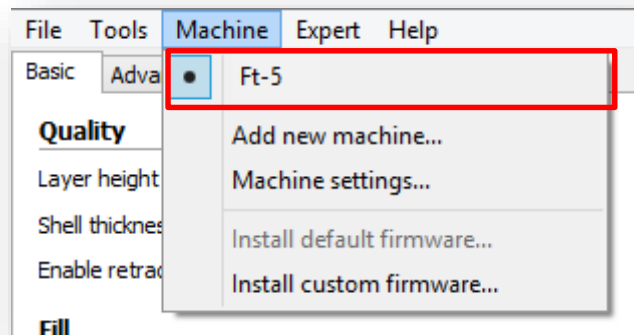

2. Load the desired model file (typically STL but CURA does accept other formats) by clicking on the Load icon in the top left of the print window.

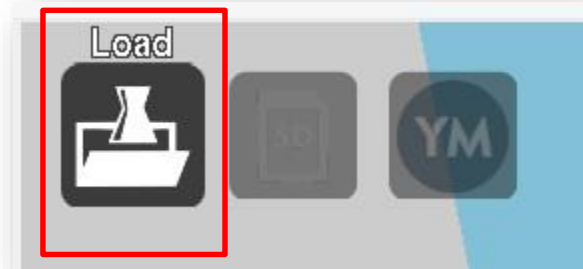



- Once the model has loaded, reposition the part to the desired location and orientation on the printer bed. To reposition the model, click, hold, and drag it to the desired location in the printer's volume, identified by the shaded blue area.

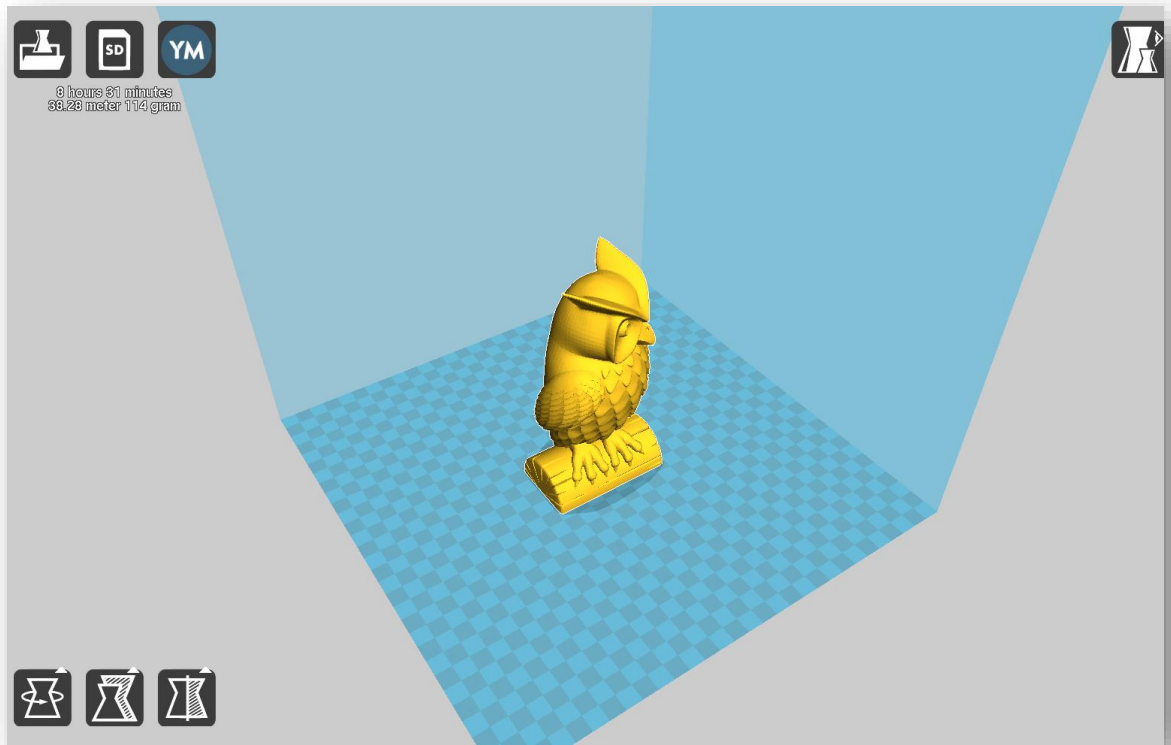

**Note:** the orientation will determine if support structure is required. Reference the Printing Settings Definitions section for help manipulating the part.

- Verify and adjust any of the Basic and Advanced printing settings. See the Printer Settings Definitions section for more detailed information on these settings.

**Note:** Hovering the mouse over a setting will bring up a description of how the setting will affect the print.

- Plug the printer into the computer into your computer. Click the print icon in the top left of the print window to connect Cura to your printer.

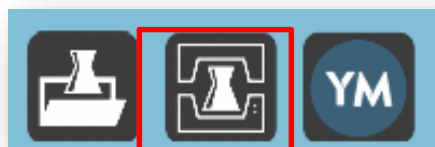

## SD Card Slot

The SD card slot at the front of the printer allows you to insert an SD card to run the machine code and print without connecting to a computer.

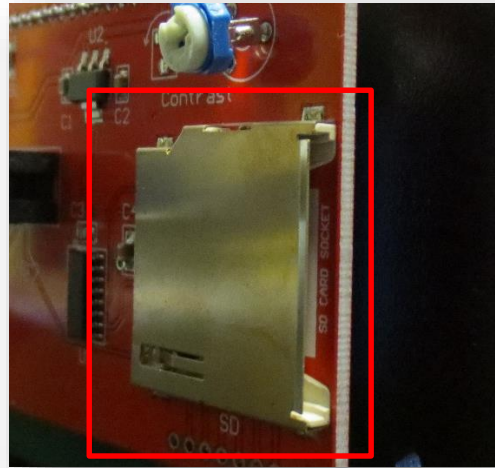

### 3) PRINTING FROM AN SD CARD

The LCD screen allows the FT-5 3D Printer to read the G-code for your print file directly from an SD card. This allows the machine to run without being connected to a computer.

#### STEP-BY-STEP PROCESS

1. Insert the SD card into the printer. The SD card slot is located next to the print bed, and to the right of the LCD screen.
2. Turn on the printer or restart if required. When an SD card is installed the machine must be restarted to recognize the card.
3. Press the control knob once to reach the Main Menu.
4. Scroll down to "Print from SD" and press the control knob again to select this function.
5. Use the control knob to scroll to the desired print file. Newly added files will usually appear at the bottom of the file list.
6. Press the control knob to select the file you want to print. The printer will heat the hot end to operating temperature and auto home the effector.
7. Watch the first layer being printed to ensure that the bed is at the correct height and properly leveled. If the bed appears to be at the wrong level stop the printing process and relevel the bed. Once printing is completed the effector will return to the home position.
8. Allow the hot end to reach room temperature. Then remove your finished masterpiece.

## PRINTER OPERATION

This section details several processes that periodically will need to be performed to keep your printer running like new.

### CHANGING FILAMENT

This section will guide you through the process of changing filament to allow you to replace fully consumed filament spools or change colors between prints. To change the filament, you must first completely remove the current filament and then install the next filament spool.

**CAUTION: The hot end will be heated to operating temperatures and can cause injury.**

#### Removal

1. Turn on the printer and preheat the hot end to the operating temperature (210 °C for PLA and 230 °C for ABS).
2. Push up on the extruder lever and slightly push in on the filament until it comes out of the tip of the nozzle. The figure below shows the extruder lever and direction to push.
3. Gently pull the filament completely out of the Bowden Tube while continuing to push up on the extruder lever.

#### Installation

1. Prep the end of the new filament by clipping it at a 45-degree angle, and straighten 2 to 4 inches of the clipped end, which will be inserted into the extruder.
2. Push up on the extruder lever and insert the filament into the extruder.
3. Continue to feed the filament through the extruder and the Hotend until it flushes out the old filament from the nozzle.
4. Release the extruder lever and you are now ready to get back to printing!

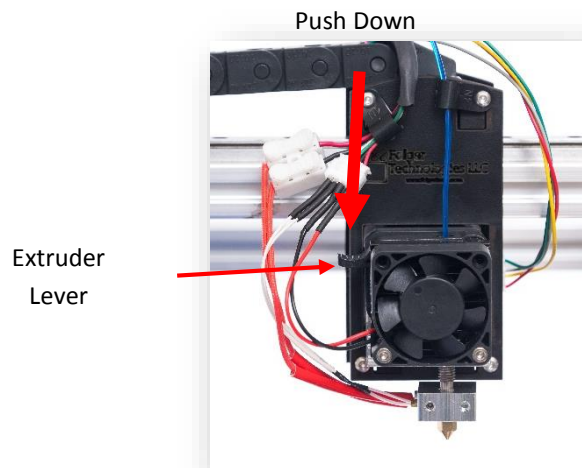

## BED PREPARATION

The bed preparation process ensures that the filament will stick to the printer bed. This process requires 3M Scotch Blue Painters Tape and a razor blade (optional).

1. Remove any old tape that needs to be replaced.
2. Apply the new Scotch Blue painters tape to the bed to replace the tape that was removed.
3. Gently press down on the new tape to smooth out the edges. Ensure there are no bubbles in the tape. Use a razor blade to trim the edges of the tape to the dimensions of the bed (optional).
4. If printing with ABS, apply a layer of glue (normal glue stick) over the area to be printed on. Allow this layer to dry before printing.

## MAINTENANCE

Regular maintenance is important for accurate worry free printing. Perform these simple steps to optimize your printing experience.

### CHECK BELT TENSION

Every few weeks it is important to make sure the belts are the correct tension, as they may stretch out during use. Follow the instructions in the Belt Tension section if you suspect a belt need to be tighten. The belts should be checked every few weeks for casual use and every week if the printer is used daily. Checking the belt tension regularly will help prevent print failures and/or damage to the printer.

### CHECK FOR LOOSE SCREWS

As you print, you may find that some screws will start to come loose. Go around the machine and make sure all of the screws are tight. Check to make sure the set screw for the hot end thermistor is tight, if the thermistor comes loose and falls out, the hot end will heat uncontrollably.

## TROUBLESHOOTING

The table below shows some of the most common problems experienced with 3D printer use and solutions to resolve them. For more troubleshooting help, visit our [FAQ page](#).

Symptom	Solution
Layers are shifting towards a tower	Check and tighten the belt on the tower that the layers are shifting towards. Also check for a loose belt pulley on the stepper motor on that tower.
Belt skipped	Check the belts for tension.
Nozzle too close to bed on first layer.	Adjust the Z endstop.
Initial Layer is not sticking	First try replacing the Scotch Blue Painter's Tape. Next, check the bed level. Finally, a thin layer of Elmer's glue (glue stick only) can be applied for maximum adhesion.
Plastic is not extruding from the nozzle.	Ensure the filament is feeding correctly and being pushed into the nozzle from the extruder. Next, verify the nozzle temperature is correctly set between 210 °C for PLA and 230 C for ABS.